

PVC-U METRIC

BEND 90°

Bocht 90°
Bogen 90°
Courbe 90°
Curva 90°
Curva 90°

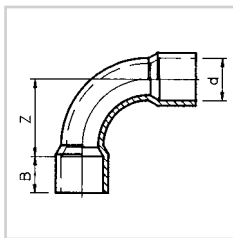

$R = 1.5d$

ART.CODE	d	Z	B	PN	QUANTITY
1.05.032	32	60	22 - 25	10	350
1.06.032	32	60	22 - 25	16	175
1.05.040	40	76	26 - 30	10	200
1.06.040	40	76	26 - 30	16	100
1.05.050	50	92	31 - 35	10	100
1.06.050	50	92	31 - 35	16	80
1.05.063	63	102	38 - 43	10	60
1.06.063	63	102	38 - 43	16	45
1.05.075	75	118	44 - 51	10	35
1.06.075	75	118	44 - 51	16	25
1.05.090	90	142	51 - 59	10	20
1.06.090	90	142	51 - 59	16	15
1.05.110	110	175	61 - 70	12.5	10
1.05.125	125	200	69 - 79	12.5	6
1.05.140	140	236	76 - 87	12.5	5
1.05.160	160	260	86 - 99	12.5	4
1.05.200	200	330	106 - 122	12.5	1
1.05.225	225	380	119 - 136	12.5	1
1.05.250	250	390	131 - 151	12.5	1
1.05.280	280	480	146 - 168	12.5	1
1.05.315	315	625	164 - 188	12.5	1

BEND 90°

Bocht 90°
Bogen 90°
Courbe 90°
Curva 90°
Curva 90°

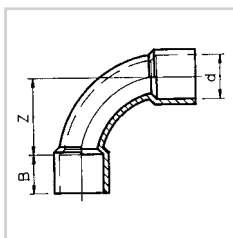

$R = 1.5d$

ART.CODE	d	Z	B	PN	QUANTITY
2.20.020	20	30	16	16	100
2.20.025	25	37.5	19	16	100
2.20.032	32	48	22	16	100
2.20.033	32	48	22	10	100
2.20.040	40	60	26	16	100
2.20.041	40	60	26	10	100
2.20.050	50	75	31	16	50
2.20.051	50	75	31	10	50

PVC-U METRIC

BEND 45°

Bocht 45°
Bogen 45°
Courbe 45°
Curva 45°
Curva 45°

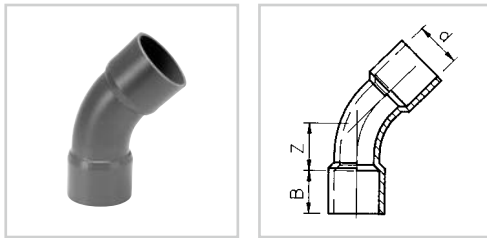

ART.CODE	d	Z	B	PN	QUANTITY
1.15.032	32	26	22 - 25	10	300
1.16.032	32	26	22 - 25	16	350
1.15.040	40	36	26 - 30	10	150
1.16.040	40	36	26 - 30	16	150
1.15.050	50	40	31 - 35	10	150
1.16.050	50	40	31 - 35	16	125
1.15.063	63	46	38 - 43	10	90
1.16.063	63	46	38 - 43	16	60
1.15.075	75	54	44 - 51	10	50
1.16.075	75	54	44 - 51	16	40
1.15.090	90	63	51 - 59	10	30
1.16.090	90	63	51 - 59	16	20
1.15.110	110	80	61 - 70	12.5	15
1.15.125	125	89	69 - 79	12.5	10
1.15.140	140	98	76 - 87	12.5	7
1.15.160	160	119	86 - 99	12.5	5
1.15.200	200	143	106 - 122	12.5	1
1.15.225	225	166	119 - 136	12.5	1
1.15.250	250	190	131 - 151	12.5	1
1.15.280	280	214	146 - 168	12.5	1
1.15.315	315	236	164 - 188	12.5	1

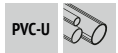

$R = 1.5d$

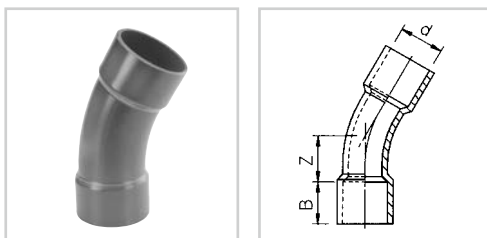

BEND 30°

Bocht 30°
Bogen 30°
Courbe 30°
Curva 30°
Curva 30°

ART.CODE	d	Z	B	PN	QUANTITY
1.17.063	63	48	38 - 43	10	90
1.17.090	90	65	51 - 59	10	30
1.17.110	110	79	61 - 70	12.5	15
1.17.125	125	92	69 - 79	12.5	10
1.17.140	140	106	76 - 87	12.5	7
1.17.160	160	122	86 - 99	12.5	5
1.17.200	200	147	106 - 122	12.5	1
1.17.225	225	155	119 - 136	12.5	1
1.17.250	250	195	131 - 151	12.5	1
1.17.280	280	213	146 - 168	12.5	1
1.17.315	315	240	164 - 188	12.5	1



$R = 2.5d$

PVC-U METRIC

BEND 22.5°

Bocht 22.5°
Bogen 22.5°
Courbe 22.5°
Curva 22.5°
Curva 22.5°

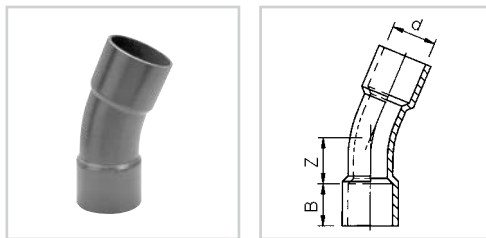

ART.CODE	d	Z	B	PN	QUANTITY
1.19.090	90	48	51 - 59	10	30
1.19.110	110	64	61 - 70	12.5	15
1.19.125	125	75	69 - 79	12.5	10
1.19.140	140	81	76 - 87	12.5	7
1.19.160	160	92	86 - 99	12.5	5
1.19.200	200	127	106 - 122	12.5	1



BEND 15°

Bocht 15°
Bogen 15°
Courbe 15°
Curva 15°
Curva 15°

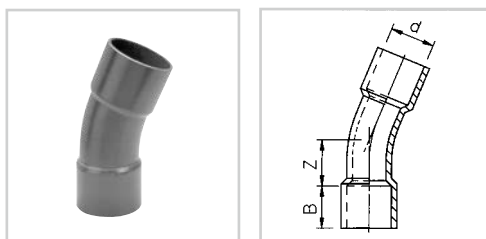

ART.CODE	d	Z	B	PN	QUANTITY
1.14.090	90	37	51 - 59	10	25
1.14.110	110	46	61 - 70	12.5	15
1.14.125	125	53	69 - 79	12.5	10
1.14.140	140	60	76 - 87	12.5	7
1.14.160	160	70	86 - 99	12.5	6
1.14.200	200	87	106 - 122	12.5	1
1.14.225	225	98	119 - 136	12.5	1
1.14.250	250	106	131 - 151	12.5	1
1.14.280	280	116	146 - 168	12.5	1
1.14.315	315	128	164 - 188	12.5	1



4D RADIUS BEND 83° (97°)

4d radius bocht 83° (97°)
4d radius bogen 83° (97°)
4d radius courbe 83° (97°)
4d radius curva 83° (97°)
4d radius curva 83° (97°)

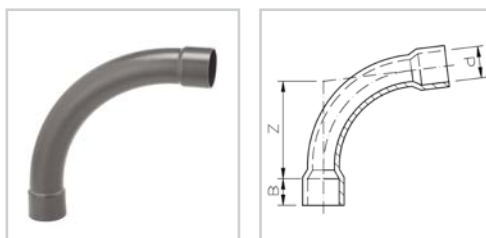

ART.CODE	d	Z	B	PN	QUANTITY
1.02.063	63	227	38 - 43	10	30



$R = 4d$

PVC-U METRIC

4D RADIUS BEND 90°

4d radius bocht 90°
4d radius bogen 90°
4d radius courbe 90°
4d radius curve 90°
4d radius curve 90°

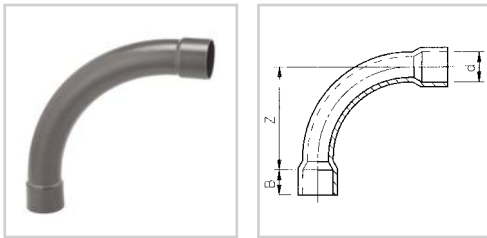

ART.CODE	d	Z	B	PN	QUANTITY
1.03.063	63	256	38 - 43	10	30



$$R = 4d$$

4D RADIUS BEND 45°

4d radius bocht 45°
4d radius bogen 45°
4d radius courbe 45°
4d radius curve 45°
4d radius curve 45°

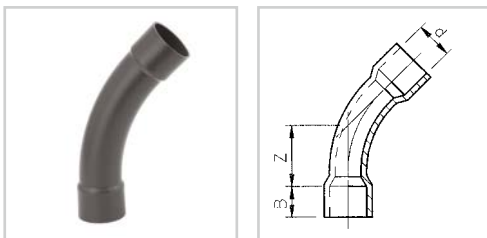

ART.CODE	d	Z	B	PN	QUANTITY
1.13.063	63	159.5	38 - 43	10	50



$$R = 4d$$

S-BEND

S-bocht
S-bogen
Courbe en s
Curva-s
Carva-pasamuro

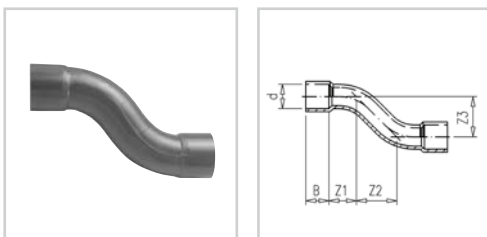

ART.CODE	d	B	Z1	Z2	Z3	PN	QUANTITY
1.10.032	32	22 - 25	35	57	60	10	150
1.10.040	40	26 - 30	40	63	60	10	150
1.10.050	50	31 - 35	50	55	85	10	80



PVC-U METRIC

ELBOW 90°

Knie 90°
Winkel 90°
Coude 90°
Gomito 90°
Code 90°



TYPE A: $R = 0,5d$

TYPE B: $R = 0,75d$

* = kiwa norm PN 16

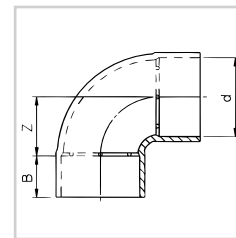
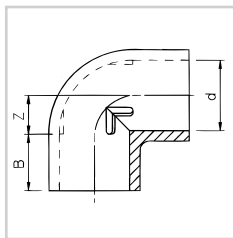

TYPE A

TYPE B

ART.CODE	d	Z	B	TYPE	PN	QUANTITY
2.25.010	10	6	12	A	16	250 (5x50)
2.25.012*	12	7	12	A	16	250 (5x50)
2.25.016*	16	9	15	A	16	250 (5x50)
2.25.020*	20	11.5	16	A	16	200 (4x50)
2.25.025*	25	14	20	A	16	350
2.25.032*	32	19	22	A	16	250
2.25.033	32	19	22	A	10	250
2.25.040*	40	22	26	A	16	175
2.25.041	40	22	26	A	10	175
2.25.050*	50	27.5	31	A	16	100
2.25.051	50	27.5	31	A	10	100
2.25.063*	63	33.5	38	A	16	50
2.25.064	63	33.5	38	A	10	55
2.25.075	75	39.5	44	A	16	30
2.25.076	75	39.5	44	A	10	30
2.25.090	90	47.5	51	A	16	17
2.25.091	90	45	51	A	10	17
2.25.110	110	57	61	A	16	12
2.25.111	110	55	61	A	10	12
2.25.125	125	63.5	69	A	16	6
2.25.140	140	71	76	A	16	5
2.25.160	160	83	87	A	16	2
2.25.200	200	106	107	A	10	1
2.25.225	225	118.5	120	A	10	1
2.25.250	250	131	132	A	10	1
2.25.280	280	210	147	B	10	1
2.25.315	315	237	165	B	10	1
2.25.400	400	300	207	B	6	1

PVC-U METRIC

ELBOW 90°

Knie 90°
Winkel 90°
Coude 90°
Gomito 90°
Code 90°

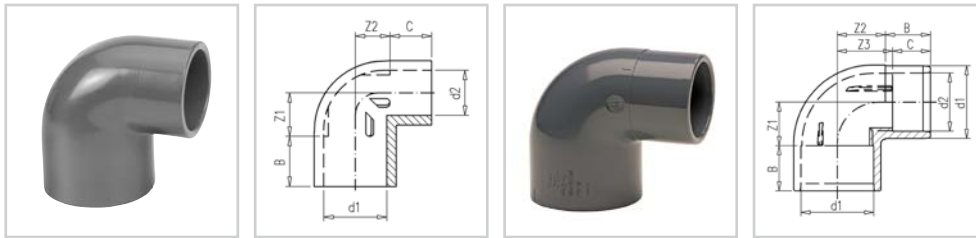

TYPE A

TYPE B

ART.CODE	d1	d1	Z1	Z2	Z3	B	C	TYPE	PN	QUANTITY
2.26.011	40	32	23	23	-	26	22	A	10	200
2.26.021	50	32	28	33	-	31	22	A	10	150
2.26.031	50	40	28	29	-	31	26	A	10	135
2.26.032	50	40	30	33	38	31	26	B	10	100
2.26.042	63	50	46	44	50	37.5	31	B	10	50



reducing
verlopend
reduzierend
réduisant
ridotto
reducida

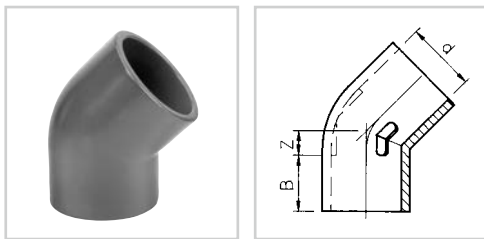

ELBOW 45°

Knie 45°
Winkel 45°
Coude 45°
Gomito 45°
Code 45°

ART.CODE	d	Z	B	PN	QUANTITY
2.30.010	10	3	12	16	150 (3x50)
2.30.012*	12	3.5	12	16	150 (3x50)
2.30.016*	16	4.5	14	16	150 (3x50)
2.30.020*	20	5	16	16	150 (3x50)
2.30.025*	25	6	19	16	150
2.30.032*	32	7	22	16	300
2.30.040*	40	10	26	16	150
2.30.050*	50	12	31	16	75
2.30.051	50	12	31	10	100
2.30.063*	63	14	38	16	65
2.30.064	63	14	38	10	70
2.30.075	75	18	44	16	35
2.30.090	90	19	52	16	24
2.30.110	110	26	62	16	12
2.30.125	125	26.5	69	16	6
2.30.140	140	30	76	16	6
2.30.160	160	35	86	16	2
2.30.200	200	49	107	10	1
2.30.225	225	54	120	10	1
2.30.250	250	60	132	10	1
2.30.280	280	66	147	10	1
2.30.315	315	74	165	10	1
2.30.400	400	86.5	207	6	1



* = kiwa norm PN 16

kiwa

PVC-U METRIC

ELBOW 45°

Knie 45°
Winkel 45°
Coude 45°
Gomito 45°
Code 45°

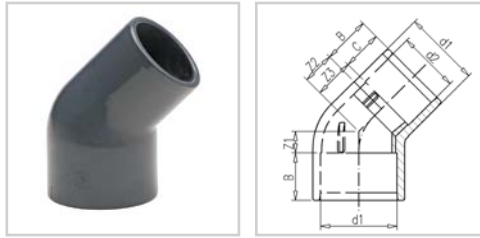

ART.CODE	d1	d2	Z1	Z2	Z3	B	C	PN	QUANTITY
2.32.050	50	40	14	21	26	31	26	16	100
2.32.063	63	50	17.5	26.5	32.5	37.5	31.5	16	50

ELBOW 90°

Knie 90°
Winkel 90°
Coude 90°
Gomito 90°
Code 90°

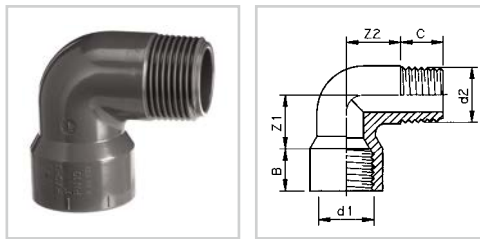

ART.CODE	d1	d2	Z1	Z2	B	C	PN	QUANTITY
2.28.020	½" (F)	½" (M)	20.5	20.5	16	16	10	200
2.28.025	¾" (F)	¾" (M)	24.5	24.5	17	17	10	300
2.28.032	1" (F)	1" (M)	30	30	21	21	10	200

ELBOW 90°

Knie 90°
Winkel 90°
Coude 90°
Gomito 90°
Code 90°

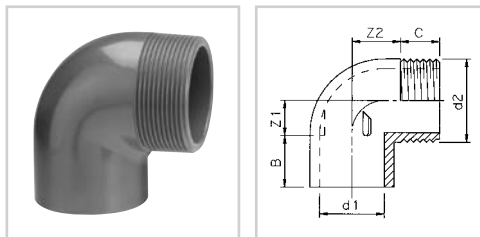

ART.CODE	d1	d2	Z1	Z2	B	C	PN	QUANTITY
2.29.010	20	¾" (M)	11	17	16	16	16	200
2.29.020	25	1" (M)	17	20	19	19	16	350
2.29.030	32	¾" (M)	21	29	22	19	10	250
2.29.040	32	1" (M)	21	30	22	19	10	250
2.29.051	32	1¼" (M)	17	24	22	21	10	250
2.29.061	40	1¼" (M)	23	28	26	21	10	200
2.29.071	40	1½" (M)	23	28	26	21	10	175
2.29.081	50	1¼" (M)	28	34	31	21	10	150
2.29.091	50	1½" (M)	28	34	31	21	10	125
2.29.101	50	2" (M)	28	34	31	26	10	100

ELBOW 90°

Knie 90°
Winkel 90°
Coude 90°
Gomito 90°
Code 90°

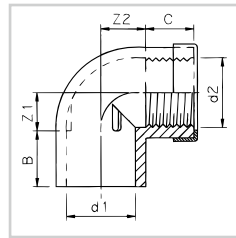
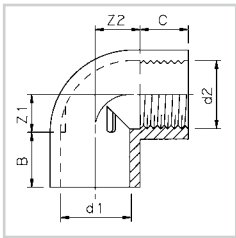

TYPE A

TYPE B

ART.CODE	d1	d2	Z1	Z2	B	C	TYPE	PN	QUANTITY
2.35.016	16	3/8" (F)	9	11	14	12	A	10	200
2.40.016	16	3/8" (F)	11	11	14	12	B	16	50
2.35.020	20	1/2" (F)	11	15	16	16	A	10	200
2.40.020	20	1/2" (F)	11	15	17	15	B	16	50
2.35.025	25	3/4" (F)	13.5	15.5	19	17	A	10	300
2.40.025	25	3/4" (F)	13.5	15.5	20	16.5	B	16	50
2.35.032	32	1" (F)	17	18	22	21	A	10	100
2.40.032	32	1" (F)	17	18	22	21	B	16	50
2.35.040	40	1 1/4" (F)	21	24	26	23	A	10	100
2.40.040	40	1 1/4" (F)	21	24	26	23	B	10	50
2.35.050	50	1 1/2" (F)	28	32	31	27	A	10	100
2.40.050	50	1 1/2" (F)	28	32	31	27	B	16	50
2.35.063	63	2" (F)	34	41	38	31	A	10	50
2.40.063	63	2" (F)	34	41	38	31	B	16	25
2.40.075	75	2 1/2" (F)	39	47	44	36	B	10	30
2.40.090	90	3" (F)	46	58	51	39	B	10	17
2.40.110	110	4" (F)	56	78	61	39	B	10	12



TYPE A

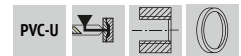

TYPE B

PVC-U METRIC

TEE 90°

T-Stuk 90°
T-Stück 90°
TE 90°
TI 90°
TE 90°

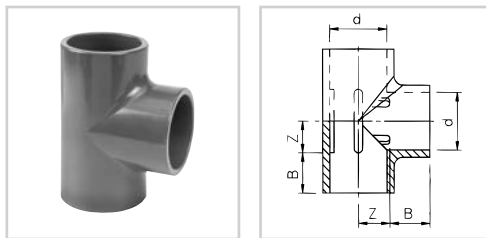

* = kiwa norm PN 16



ART.CODE	d	Z	B	PN	QUANTITY
2.01.010	10	6	12	16	250 (5x50)
2.01.012*	12	7	12	16	250 (5x50)
2.01.016*	16	9.5	14	16	200 (4x50)
2.01.020*	20	11.5	16	16	100 (2x50)
2.01.025*	25	14.5	19	16	250
2.01.032*	32	17.5	22	16	225
2.01.033	32	17	22	10	250
2.01.040*	40	23.5	26	16	125
2.01.041	40	23	26	10	125
2.01.050*	50	27	32	16	75
2.01.051	50	27	32	10	75
2.01.063*	63	35	38	16	38
2.01.064	63	34	38	10	38
2.01.075	75	40	44	16	24
2.01.076	75	40	44	10	24
2.01.090	90	48.5	51	16	14
2.01.091	90	48.5	51	10	14
2.01.110	110	59	61	16	7
2.01.111	110	59	61	10	7
2.01.125	125	66	69	16	4
2.01.140	140	73.5	76	16	3
2.01.160	160	85.5	86	16	2
2.01.200	200	106.5	107	10	1
2.01.225	225	118.5	120	10	1
2.01.250	250	131	132	10	1
2.01.280	280	152	146	10	1
2.01.315	315	168	164	10	1
2.01.400	400	214	206	6	1

PVC-U METRIC

TEE 90°

T-Stuk 90°
T-Stück 90°
TE 90°
TI 90°
TE 90°

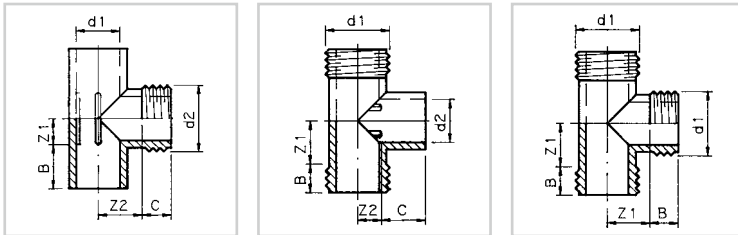

TYPE A

TYPE B

TYPE C

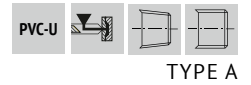

* Straight threaded
Rechte schroefdraad
Geradem gewinde
Filetage droit
Filetto diritto
Recto rosca

ART.CODE	d1	d2	Z1	Z2	B	C	TYPE	PN	QUANTITY
2.05.015	20	¾" (M)	11	17	16	17	A	16	250
2.05.020	25	¾" (M)	14	20	19	16	A	16	300
2.05.025	32	1" (M)	14	20	19	14	A	16	250
2.05.030	32	¾" (M)	17	23	22	16	A	16	200
2.05.035	32	1" (M)	17	23	22	19	A	16	200
2.05.041	1" (M)	32	31	20	19	22	B	10	250
2.05.046	32	1¼" (M)	17	23	22	19	A	10	225
2.05.051	1¼" (M)	32	26	17	21	22	B	10	175
2.05.056	1¼" (M)	-	26	-	21	-	C	10	175
2.05.060	40	1" (M)	23	27	26	19	A	16	125
2.05.066	40	1¼" (M)	23	27	26	21	A	10	140
2.05.067	1¼" (M)	40	27	23	21	26	B	10	150
2.05.071	40	1½" (M)	23	27	26	21	A	10	130
2.05.075	50	1" (M)	28	33	31	19	A	16	90
2.05.081	50	1¼" (M)	28	33	31	21	A	10	90
2.05.086	50	1½" (M)	28	33	31	21	A	10	90
2.05.090*	63	1" (M)	34	42	38	19	A	16	50
2.05.095*	63	1¼" (M)	34	42	38	21	A	16	45
2.05.100*	63	1½" (M)	34	42	38	21	A	16	40
2.05.105*	63	2" (M)	34	42	38	26	A	16	40
2.05.110*	75	1¼" (M)	40	50	44	21	A	16	30
2.05.115*	75	1½" (M)	40	50	44	21	A	16	30
2.05.120*	75	2" (M)	40	50	44	26	A	16	28

PVC-U METRIC

REDUCING TEE 90°

T-Stuk verlopend 90°
T-Stück reduzierent 90°
TE réduit 90°
TI ridotto 90°
TE reducida 90°

PVC-U

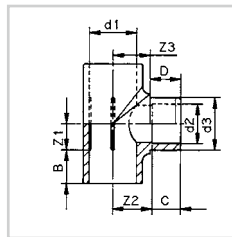
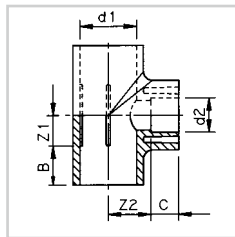
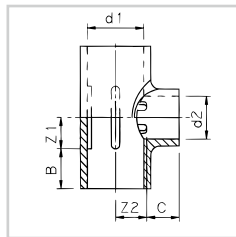

TYPE A

TYPE B

TYPE C

ART.CODE	d1	d2	d3	Z1	Z2	Z3	B	C	D	TYPE	PN	QUANTITY
2.03.005	25	16	-	14.5	14	-	19	14	-	A	16	300
2.03.010	25	20	-	14	15.5	-	19	16	-	A	16	300
2.03.013	32	16	-	17	17	-	22	14	-	A	16	200
2.03.015	32	20	-	17	19	-	22	16	-	A	16	250
2.03.020	32	25	-	17	19	-	22	19	-	A	16	200
2.03.022	40	16	-	23	24	-	26	14	-	A	16	150
2.03.023	40	20	-	23	23	-	26	16	-	A	16	150
2.03.025	40	25	-	23	23	-	26	19	-	A	16	140
2.03.031	40	32	-	23	24	-	26	22	-	A	10	140
2.03.032	40	32	-	23	23	-	26	22	-	A	16	140
2.03.033	50	20	-	28	30.5	-	31	16	-	A	16	100
2.03.035	50	25	-	28	29.5	-	31	19	-	A	10	100
2.03.041	50	32	-	28	28.5	-	31	22	-	A	16	90
2.03.042	50	32	-	28	28.5	-	31	22	-	A	10	90
2.03.046	50	40	-	28	29	-	31	26	-	A	16	90
2.03.047	50	40	50	28	38	33	31	26	31	C	10	75
2.03.048	50	40	-	28	28.5	-	31	26	-	A	16	90
2.03.049	63	20	-	34	37	-	38	16	-	A	16	50
2.03.050	63	25	-	33.5	34	-	38	19	-	A	16	50
2.03.055	63	32	-	34.5	36	-	38	22	-	A	16	50
2.03.060	63	40	-	32.5	32.5	-	38	26	-	A	16	45
2.03.063	63	40	50	34.5	46.5	41	38	26	31	C	16	40
2.03.065	63	50	-	33.5	34	-	38	31	-	A	16	40
2.03.070	75	32	-	40	43	-	44	22	-	A	16	30
2.03.075	75	40	-	40	40.5	-	44	26	-	A	16	30
2.03.080	75	50	-	40	40.5	-	44	31	-	A	16	28
2.03.085	75	63	-	40	40.5	-	44	38	-	A	16	25
2.03.090	90	32	-	46	55	-	51	22	-	A	16	17
2.03.094	90	40	-	46	60	-	51	26	-	A	16	17
2.03.095	90	50	-	46	55	-	51	31	-	A	16	17
2.03.097	90	63	-	46	55	-	51	38	-	A	16	15
2.03.100	90	75	-	46	55	-	51	44	-	A	16	14
2.03.105	100	32	-	56	66.5	-	61	22	-	A	16	9

REDUCING TEE 90°

T-Stuk verlopend 90°
T-Stück reduziert 90°
TE réduit 90°
TI ridotto 90°
TE reducida 90°



ART.CODE	d1	d2	d3	Z1	Z2	Z3	B	C	D	TYPE	PN	QUANTITY
2.03.107	110	40	-	56	72	-	61	26	-	A	16	9
2.03.110	110	50	-	56	66.5	-	61	31	-	A	16	9
2.03.111	110	63	-	56	65	-	61	38	-	A	16	9
2.03.112	110	75	-	56	65	-	61	44	-	A	16	8
2.03.115	110	90	-	56	65	-	61	51	-	A	16	8
2.03.120	125	50	-	64	75	-	69	31	-	A	16	4
2.03.123	125	63	-	64	87	-	69	38	-	B	16	4
2.03.124	125	75	-	64	81	-	69	44	-	B	16	4
2.03.125	125	90	-	64	75	-	69	51	-	A	10	4
2.03.126	125	110	-	65.5	74	-	69	61	-	B	16	4
2.03.130	140	50	-	71.5	82	-	76	31	-	A	16	4
2.03.135	140	75	-	71.5	78	-	76	44	-	A	16	4
2.03.137	140	90	-	71.5	81	-	76	51	-	B	16	4
2.03.140	140	110	-	71.5	73.5	-	76	61	-	A	16	4
2.03.153	160	75	-	81	98	-	86	44	-	B	16	2
2.03.154	160	90	-	81	91	-	86	51	-	B	16	2
2.03.155	160	110	-	81	91	-	86	61	-	A	16	3
2.03.156	160	125	-	81	100	-	86	69	-	B	16	2
2.03.165	200	110	-	106	131	-	107	61	-	B	10	1
2.03.170	200	160	-	106	106	-	107	86	-	A	10	1
2.03.185	225	110	-	119	143	-	120	61	-	B	10	1
2.03.190	225	160	-	119	119	-	120	86	-	A	10	1
2.03.205	250	160	-	131	151	-	132	86	-	B	10	1
2.03.210	250	200	-	131	131	-	132	106	-	A	10	1
2.03.225	280	160	-	120	180	-	146	86	-	B	10	1
2.03.230	280	225	-	120	149	-	146	119	-	A	10	1
2.03.245	315	160	-	120	197	-	164	86	-	B	10	1
2.03.250	315	225	-	120	165	-	164	119	-	A	10	1
2.03.265	400	225	-	163	258	-	206	119	-	B	6	1
2.03.270	400	315	-	163	213	-	206	164	-	A	6	1

PVC-U METRIC

TEE 90°

T-Stuk 90°
T-Stück 90°
TE 90°
TI 90°
TE 90°



TYPE A

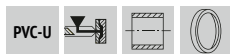

TYPE B

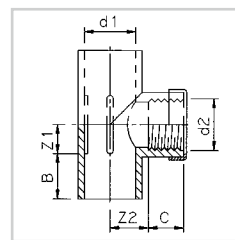
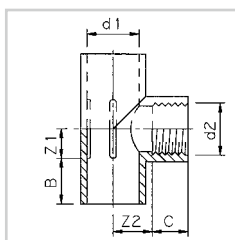

TYPE A

TYPE B

ART.CODE	d1	d2	Z1	Z2	B	C	TYPE	PN	QUANTITY
2.07.016	16	3/8" (F)	9	11	14	12	A	10	100
2.07.017	16	3/8" (F)	9	11	14	12	B	16	50
2.07.020	20	1/2" (F)	11	12	16	16	A	10	100
2.07.021	20	1/2" (F)	11	12	16	16	B	16	50
2.07.023	25	1/2" (F)	14	14	19	16	A	10	200
2.07.024	25	1/2" (F)	14	14	19	16	B	16	50
2.07.025	25	3/4" (F)	14	16	19	17	A	10	200
2.07.026	25	3/4" (F)	14	16	19	17	B	16	50
2.07.028	32	1/2" (F)	17	17	22	16	A	10	100
2.07.029	32	1/2" (F)	17	17	22	16	B	16	50
2.07.032	32	1" (F)	17	19	22	20	A	10	100
2.07.033	32	1" (F)	17	19	22	20	B	16	50
2.07.040	40	1 1/4" (F)	21	25	26	22	A	10	100
2.07.041	40	1 1/4" (F)	21	25	26	22	B	16	50
2.07.050	50	1 1/2" (F)	26	35	31	22	A	10	50
2.07.051	50	1 1/2" (F)	26	35	31	22	B	16	50
2.07.063	63	2" (F)	32.5	41.5	38	29	A	10	25
2.07.064	63	2" (F)	32.5	41.5	38	29	B	16	25
2.07.076	75	2 1/2" (F)	38.5	48.5	44	34	B	10	18
2.07.091	90	3" (F)	46	56	51	41	B	10	10
2.07.111	110	4" (F)	56	77	61	41	B	10	7

TEE 45°

T-Stuk 45°
T-Stück 45°
TE 45°
TI 45°
TE 45°

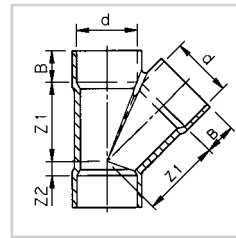
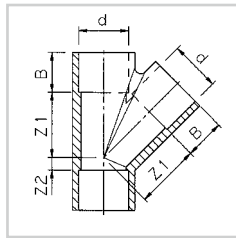

TYPE A

TYPE B

ART.CODE	d1	Z1	Z2	B	TYPE	PN	QUANTITY
2.08.010	10	18	4	12	A	16	150
2.08.012	12	21	4	12	A	16	150
2.08.016	16	25	5	14	A	16	150
2.08.020	20	29.5	6	17	A	16	150
2.08.025	25	35.5	7.5	19	A	16	150
2.08.032	32	44.5	9	23	A	16	100
2.08.040	40	56	10	27	A	16	75
2.08.050	50	69	12	32	A	16	40
2.08.063	63	86	14	38	A	10	30
2.08.075	75	102	17	44	A	10	16
2.08.090	90	121	20	51	A	10	9
2.08.111	110	159	32	61	B	10	3
2.08.125	125	167	30	69	A	10	3
2.07.140	140	190	34	76	A	10	2
2.08.161	160	213	41	86	B	10	2
2.08.200	200	266	49	107	B	6	1
2.08.225	225	297	55	120	B	6	1
2.08.250	250	330	60	132	B	6	1

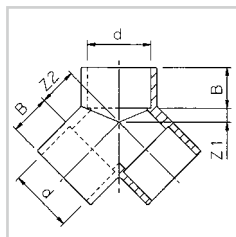

Y-ELBOW

Y-Stuk
Y-Winkel
Y-coude
Gomito a Y
Y griega



ART.CODE	d1	Z1	Z2	B	PN	QUANTITY
2.09.050	50	12	31	31	16	70
2.09.063	63	15	37	38	16	35
2.09.075	75	17	43	44	16	20

PVC-U METRIC

Y-BEND

Stroom Y-Stuk
Y-Bogen
Y-Courbe
Curva a Y
Y curva con injerto

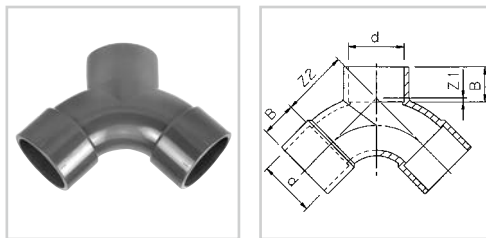

ART.CODE	d1	Z1	Z2	B	PN	QUANTITY
2.09.051	50	-3	62	31	16	55
2.09.064	63	-3	77	38	10	25

CROSS

Kruisstuk
Kreuzstück
Croix
Croce
Cruz

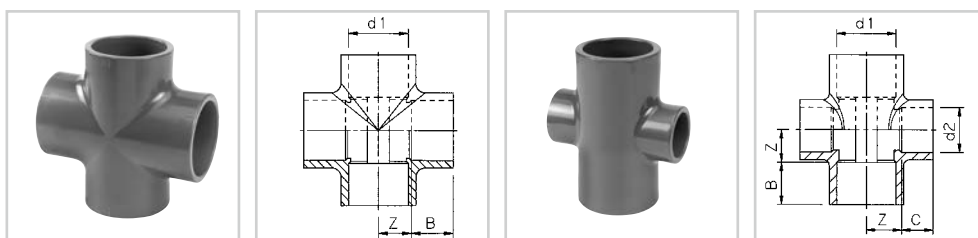

TYPE A

TYPE B



ART.CODE	d1	d2	Z	B	C	TYPE	PN	QUANTITY
2.50.010	10	-	6.5	12	-	A	16	150 (3x50)
2.50.012	12	-	7.5	12	-	A	16	150 (3x50)
2.50.016	16	-	9.5	14	-	A	16	150 (3x50)
2.50.020	20	-	11.0	16	-	A	16	100 (2x50)
2.50.025	25	-	13.5	19	-	A	16	150
2.50.032	32	-	17.0	22	-	A	16	150
2.50.039	40	32	21.0	26	22	B	16	100
2.50.040	40	-	21.0	26	-	A	16	90
2.50.049	50	32	28.0	31	22	B	16	70
2.50.050	50	-	26.0	31	-	A	16	54
2.50.063	63	-	34	38	-	A	16	25
2.50.075	75	-	40	44	-	A	10	16
2.50.090	90	-	48	51	-	A	10	10
2.50.110	110	-	59	61	-	A	10	5

SOCKET

Sok
Muffe
Manchon
Manicotto
Manguito enchufe

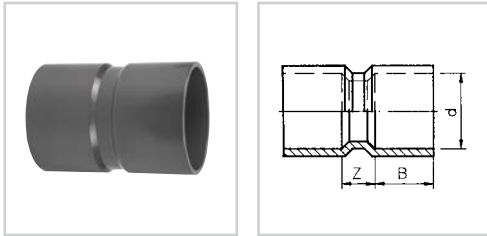

ART.CODE	d	Z	B	TYPE	PN	QUANTITY
1.20.025	25	9	19	A	10	450
1.20.032	32	12	22	A	10	400
1.20.040	40	12	26	A	10	300
1.20.050	50	12	31	A	10	250
1.20.063	63	18	38	A	10	125
1.20.075	75	19	44	A	10	100
1.20.090	90	22	51	A	10	56
1.23.090	90	32	51 - 53	B	16	56
1.20.110	110	19	61	A	10	33
1.23.110	110	41	61 - 64	B	16	25
1.20.125	125	36	69 - 72	B	7.5	22
1.23.125	125	47	69 - 72	B	16	16
1.20.140	140	46	76 - 80	B	7.5	10
1.23.140	140	60	76 - 80	B	16	10
1.20.160	160	46	86 - 90	B	7.5	10
1.23.160	160	60	86 - 90	B	16	10
1.20.200	200	48	106 - 111	B	7.5	9
1.23.200	200	63	106 - 111	B	12.5	1
1.20.225	225	65	119 - 125	B	7.5	1
1.23.225	225	74	119 - 125	B	12.5	1
1.20.250	250	68	131 - 137	B	7.5	1
1.23.250	250	85	131 - 137	B	10	1
1.20.280	280	100	146 - 153	B	10	1
1.20.315	315	75	164 - 172	B	7.5	1
1.23.315	315	90	164 - 172	B	10	1
1.20.355	355	125	184 - 193	B	6	1
1.20.400	400	140	206 - 216	B	6	1



TYPE A



TYPE B

PVC-U METRIC

SOCKET

Sok
Muffe
Manchon
Manicotto
Manguito enchufe

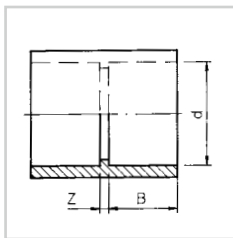

* = kiwa norm PN 16



ART.CODE	d	Z	B	PN	QUANTITY
3.90.010	10	3	12	16	300 (6x50)
3.90.012*	12	3	12	16	300 (6x50)
3.90.016*	16	3	14	16	300 (6x50)
3.90.020*	20	3	16	16	300 (6x50)
3.90.025*	25	3	19	16	200
3.90.032*	32	3	22	16	300
3.90.040*	40	5	26	16	200
3.90.050*	50	5	31	16	200
3.90.063*	63	3	38	16	100
3.90.075	75	4	44	16	65
3.90.090	90	5	51	16	36
3.90.110	110	9	61	16	24
3.90.125	125	7	69	16	12
3.90.140	140	8	76	16	10
3.90.160	160	8	86	16	8
3.90.200	200	16	106	10	1
3.90.225	225	16	119	10	1
3.90.250	250	16	134	10	1
3.90.280	280	16	149	10	1
3.90.315	315	16	166	10	1

3.90.355 ref. 1.20.355 page 29

3.90.400 ref. 1.20.400 page 29

REDUCING SOCKET

Verloopsok
Reduktionmuffe
Manchon réduit
Manicotto di riduzione
Manguito de reducción

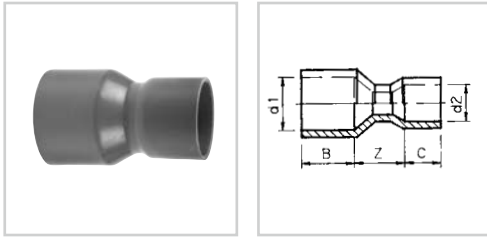

ART.CODE	d1	d2	Z	B	C	PN	QUANTITY
1.30.030	63	50	32	38 - 40	31 - 35	12.5	150
1.30.035	75	50	37	44 - 46	31 - 35	7.5	100
1.30.040	75	63	33	44 - 46	38 - 43	12.5	100
1.30.045	90	50	35	51 - 53	31 - 35	12.5	50
1.30.050	90	63	55	51 - 53	38 - 43	10	50
1.30.055	90	75	40	51 - 53	44 - 51	12.5	72
1.30.060	110	75	65	61 - 64	44 - 51	7.5	50
1.30.065	110	90	60	61 - 64	51 - 59	12.5	45
1.30.070	125	90	70	69 - 72	51 - 59	10	24
1.30.075	125	110	60	69 - 72	61 - 70	10	24
1.30.078	140	110	55	76 - 80	61 - 70	6	15
1.30.079	140	125	65	76 - 80	69 - 79	10	12
1.30.080	160	110	95	86 - 90	61 - 70	6	12
1.30.085	160	125	80	86 - 90	69 - 79	10	12
1.30.087	160	140	70	86 - 90	76 - 87	10	8
1.30.090	200	125	120	106 - 111	69 - 79	6	6
1.30.092	200	140	115	106 - 111	76 - 87	6	8
1.30.095	200	160	100	106 - 111	86 - 99	10	8
1.30.096	225	160	125	119 - 125	86 - 99	6	1
1.30.097	225	200	80	119 - 125	106 - 122	10	1
1.30.100	250	200	115	131 - 137	106 - 122	10	1
1.30.103	250	225	90	131 - 137	119 - 136	10	1
1.30.110	280	225	140	146 - 153	119 - 136	6	1
1.30.113	280	250	115	146 - 153	131 - 151	10	1
1.30.117	315	225	155	164 - 172	119 - 136	6	1
1.30.120	315	250	200	164 - 172	131 - 151	6	1
1.30.123	315	280	175	164 - 172	146 - 168	10	1
1.30.125	355	315	175	184 - 193	164 - 188	6	1
1.30.130	400	315	165	206 - 216	164 - 188	6	1
1.30.132	400	355	155	206 - 216	184 - 211	6	1

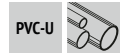

PVC-U METRIC

REDUCING SOCKET INSERT

Verloopsokinet
Reduktionsmuffe Einsatz
Manchon réduit M/F
Riduzione inserire
Reducción concéntrica

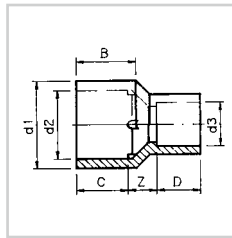
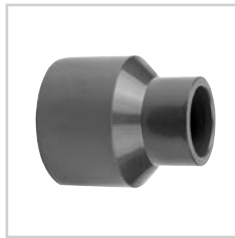

ART.CODE	d1	d2	d1	Z	B	C	D	PN	QUANTITY
3.92.010	10	6	8	2	12	12	12	16	250
3.92.012	12	8	10	2	12	12	12	16	250
3.92.016	16	12	8	6	14	12	12	16	250
3.92.017	16	12	10	6	14	12	12	16	250
3.92.020	20	16	10	6	16	14	12	16	250
3.92.021	20	16	12	6	16	14	12	16	250
3.92.025	25	20	12	9	19	16	12	16	125
3.92.026	25	20	16	7	19	16	14	16	125
3.92.032	32	25	16	9.5	22	19	14	16	125
3.92.033	32	25	20	7.5	22	19	16	16	125
3.92.040	40	32	16	14	26	22	14	16	125
3.92.041	40	32	20	12	26	22	16	16	125
3.92.042	40	32	25	9	26	22	19	16	125
3.92.050	50	40	20	17	31	26	16	16	75
3.92.051	50	40	25	14	31	26	19	16	75
3.92.052	50	40	32	11	31	26	22	16	75
3.92.053	50	40	40	4	31	26	26	16	75
3.92.063	63	50	25	20	38	31	19	16	75
3.92.064	63	50	32	17	38	31	22	16	75
3.92.065	63	50	40	13	38	31	26	16	75
3.92.066	63	50	50	4	38	31	31	16	75
3.92.075	75	63	32	23	44	38	22	16	75
3.92.076	75	63	40	19	44	38	26	16	75
3.92.077	75	63	50	14	44	38	31	16	75
3.92.090	90	75	40	25	51	44	26	16	60
3.92.091	90	75	50	20	51	44	31	16	75
3.92.092	90	75	63	13	51	44	38	16	50
3.92.110	110	90	50	30	61	51	31	16	30
3.92.111	110	90	63	23	61	51	38	16	30
3.92.112	110	90	75	17	61	51	44	16	36
3.92.124	125	110	50	39	69	61	31	16	24
3.92.125	125	110	63	32	69	61	38	16	24
3.92.126	125	110	75	26	69	61	44	16	24
3.92.127	125	110	90	19	69	61	51	16	24
3.92.140	140	125	75	33	76	69	44	16	24
3.92.141	140	125	90	26	76	69	51	16	24
3.92.142	140	125	110	16	76	69	61	16	14
3.92.160	160	140	90	40	86	76	51	16	15
3.92.161	160	140	110	30	86	76	61	16	15
3.92.162	160	140	125	22	86	76	69	16	10

PVC-U METRIC

ART.CODE	d1	d2	d1	Z	B	C	D	PN	QUANTITY
3.93.160	-	160	90	53.5	-	87	51	16	8
3.93.161	-	160	110	43.5	-	87	61	16	8
3.93.162	-	160	125	35.5	-	87	69	16	8
3.93.201	-	200	125	60	-	107	69	10	2
3.93.203	-	200	160	45	-	107	87	10	2
3.93.226	-	225	160	55	-	119	87	10	1
3.93.227	-	225	200	36	-	119	107	10	1
3.93.253	-	250	200	52	-	132	107	10	1
3.93.318	-	315	250	60	-	165	132	10	1

REDUCING SOCKET INSERT

Verloopsokkinzet
Reduktionsmuffe Einsatz
Manchon reduit M/F
Riduzione inserire
Reducción concéntrica

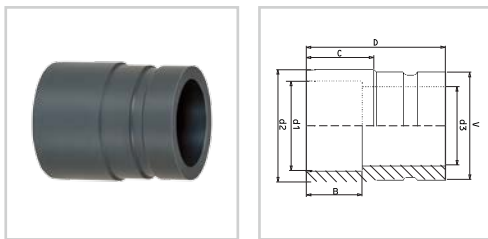

ART.CODE	d1	d2	V	d3	B	C	D	PN	Quantity
3.95.040*	32	40	1 ¼" V = 42.4	30	22.5	26.5	66	10	50
3.95.050	40	50	1 ½" V = 48.3	38.5	26	31	71	10	50
3.95.063	50	63	2" V = 60.3	44	31	38	78	10	50
3.95.075	63	75	2 ½" V = 73.0	58	38	44	84	10	50
3.95.090*	75	90	3" V = 88.9	74	44	51	91	10	36

GROOVED TRANSITION SOCKET

Übergangssok
Übergangs Muffe
Manchon de transition
Manicotto di transizione
Manguito de transition



**Made from pipe*

*For connection to
Victaulic® grooved products*

*Victaulic® is a
registered trademark
of Victaulic Company*

PVC-U METRIC

ADAPTOR SOCKET

Draadsok
Schraubmuffe
Manchon taraudé
Manicotto
Manguito transición



TYPE A

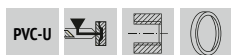

TYPE B & TYPE C

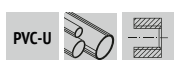

TYPE D

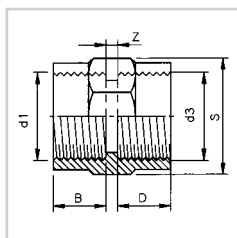

TYPE A

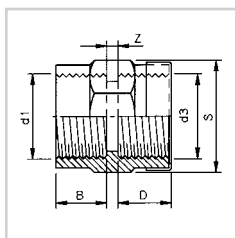

TYPE B

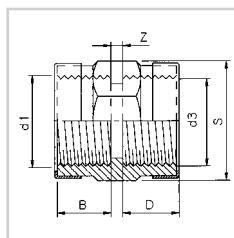

TYPE C

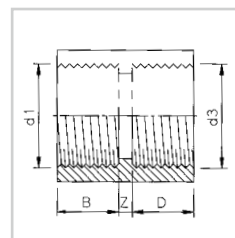

TYPE D

ART.CODE	d1	d3	Z	B	D	S	TYPE	PN	QUANTITY
3.26.010	¼" (F)	¼" (F)	2	12	12	24	A	16	100
3.26.012	¼" (F)	⅜" (F)	5	12	12	27	A	10	100
3.26.013	¼" (F)	⅜" (F)	5	12	12	27	B	16	50
3.26.015	⅜" (F)	⅜" (F)	5	12	12	27	A	10	100
3.26.016	⅜" (F)	⅜" (F)	5	12	12	27	C	16	50
3.26.017	⅜" (F)	½" (F)	6	12	15	32	A	10	100
3.26.018	⅜" (F)	½" (F)	6	12	15	32	B	16	50
3.26.019	¼" (F)	½" (F)	6	12	15	32	A	10	50
3.26.019.1	¼" (F)	½" (F)	6	12	15	32	B	16	50
3.26.020	½" (F)	½" (F)	3	15	15	32	A	10	100
3.26.021	½" (F)	½" (F)	3	15	15	32	C	16	50
3.26.021.1	⅜" (F)	¾" (F)	11	12	16	36	A	10	50
3.26.021.2	⅜" (F)	¾" (F)	11	12	16	36	B	16	50
3.26.022	½" (F)	¾" (F)	8	15	16	36	A	10	100
3.26.023	½" (F)	¾" (F)	8	15	16	36	B	16	50
3.26.025	¾" (F)	¾" (F)	7	16	16	36	A	10	100
3.26.026	¾" (F)	¾" (F)	7	16	16	36	C	16	50
3.26.027	½" (F)	1" (F)	6	15	22	46	A	10	100
3.26.027.1	½" (F)	1" (F)	6	15	22	46	C	16	50
3.26.028	¾" (F)	1" (F)	7	16	22	46	A	10	100

ADAPTOR SOCKET

Draadsok
Schraubmuffe
Manchon taraudé
Manicotto
Manguito transición

ART.CODE	d1	d3	Z	B	D	S	TYPE	PN	QUANTITY
3.26.029	¾" (F)	1" (F)	7	16	22	46	C	16	75
3.26.030	1" (F)	1" (F)	3	22	22	46	A	10	100
3.26.031	1" (F)	1" (F)	3	22	22	46	C	16	50
3.26.032	¾" (F)	1¼" (F)	9	16	23	55	A	10	150
3.26.032.1	¾" (F)	1¼" (F)	9	16	23	55	C	16	50
3.26.033	1" (F)	1¼" (F)	7	22	23	55	A	10	150
3.26.034	1" (F)	1¼" (F)	7	22	23	55	C	16	50
3.26.035	1¼" (F)	1¼" (F)	6	23	23	55	A	10	100
3.26.036	¼" (F)	1¼" (F)	6	23	23	55	C	16	50
3.26.037	1" (F)	1½" (F)	8	22	25	66	A	10	100
3.26.037.1	1" (F)	1½" (F)	8	22	25	66	C	16	75
3.26.038	1¼" (F)	1½" (F)	10	23	25	66	A	10	100
3.26.039	1¼" (F)	1½" (F)	10	23	25	66	C	16	75
3.26.040	1½" (F)	1½" (F)	10	25	25	66	A	10	100
3.26.041	1½" (F)	1½" (F)	10	25	25	66	C	16	50
3.26.042	1¼" (F)	2" (F)	13	23	28	80	A	10	60
3.26.042.1	1¼" (F)	2" (F)	13	23	28	80	C	16	50
3.26.043	1½" (F)	2" (F)	12	25	28	80	A	10	50
3.26.044	1½" (F)	2" (F)	12	25	28	80	C	16	50
3.26.045	2" (F)	2" (F)	12	28	28	80	A	10	25
3.26.046	2" (F)	2" (F)	12	28	28	80	C	16	25
3.26.049	1½" (F)	2½" (F)	18	23	31	94	C	10	25
3.26.050	2" (F)	2½" (F)	16	28	31	94	C	10	25
3.26.051	2½" (F)	2½" (F)	16	31	31	94	C	10	40
3.26.066	3" (F)	3" (F)	15	36	36	114	C	10	25
3.26.071	4" (F)	4" (F)	15	45	45	137	C	10	15
1.25.055	5" (F)	5" (F)	16	38	38	-	D	10	10
1.25.060	6" (F)	6" (F)	16	48	48	-	D	10	10

PVC-U METRIC

ADAPTOR SOCKET

Draadsok
Schraubmuffe
Manchon taraudé
Manicotto
Manguito transición



TYPE A



TYPE B

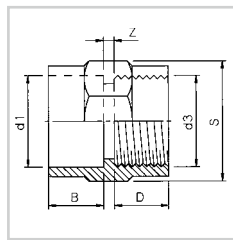
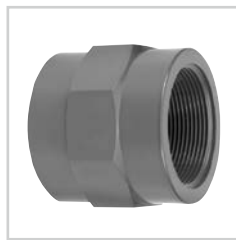

TYPE A

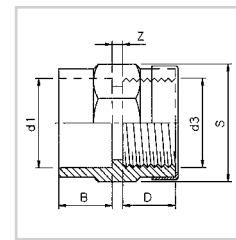

TYPE B

ART.CODE	d1	d3	Z	B	D	S	TYPE	PN	QUANTITY
3.25.010	12	1/4" (F)	2	12	12	24	A	16	100
3.25.013	16	1/4" (F)	3	14	12	27	A	16	100
3.25.015	16	3/8" (F)	3	14	12	27	A	10	100
3.25.016	16	3/8" (F)	3	14	12	27	B	16	50
3.25.017	20	1/4" (F)	5	16	12	32	A	16	50
3.25.018	20	3/8" (F)	5	16	12	32	A	16	100
3.25.020	20	1/2" (F)	2	16	15	32	A	10	100
3.25.021	20	1/2" (F)	2	16	15	32	B	16	50
3.25.026	25	1/2" (F)	5	19	15	36	A	16	100
3.25.028	25	3/8" (F)	8	19	12	36	A	16	50
3.25.030	25	3/4" (F)	4	19	16	36	A	10	100
3.25.031	25	3/4" (F)	4	19	16	36	B	16	50
3.25.036	32	1/2" (F)	5	22	15	46	A	16	100
3.25.041	32	3/4" (F)	9	22	16	46	A	16	100
3.25.045	32	1" (F)	3	22	22	46	A	10	100
3.25.046	32	1" (F)	3	22	22	46	B	16	50
3.25.048	40	3/4" (F)	6	26	16	55	A	10	150
3.25.049	40	3/4" (F)	6	26	16	55	B	16	50
3.25.051	40	1" (F)	4	26	22	55	A	16	100
3.25.055	40	1 1/4" (F)	3	26	23	55	A	10	100
3.25.056	40	1 1/4" (F)	3	26	23	55	B	16	50
3.25.058	50	1" (F)	2	31	22	66	A	10	100
3.25.059	50	1" (F)	2	31	22	66	B	16	75
3.25.061	50	1 1/4" (F)	4	31	23	66	A	16	100
3.25.065	50	1 1/2" (F)	2	31	25	66	A	10	100
3.25.066	50	1 1/2" (F)	2	31	25	66	B	16	50
3.25.067	63	1 1/4" (F)	3	38	23	80	A	10	50
3.25.067.1	63	1 1/4" (F)	3	38	23	80	B	16	50
3.25.069	63	1 1/2" (F)	7	38	25	80	A	16	50
3.25.070	63	2" (F)	3	38	27	80	A	10	50
3.25.071	63	2" (F)	3	38	27	80	B	16	25
3.25.076	75	1 1/2" (F)	5	44	23	94	A	10	40
3.25.077	75	1 1/2" (F)	5	44	23	94	B	16	40
3.25.078	75	2" (F)	4	44	27	94	A	10	45
3.25.079	75	2" (F)	4	44	27	94	B	16	35
3.25.081	75	2 1/2" (F)	4	44	31	94	B	10	25
3.25.091	90	3" (F)	3	51	36	114	B	10	24
3.25.101	110	4" (F)	5	56	45	137	B	10	15

PVC-U METRIC

ADAPTOR SOCKET

Draadsok
Schraubmuffe
Manchon taraudé
Manicotto
Manguito transición

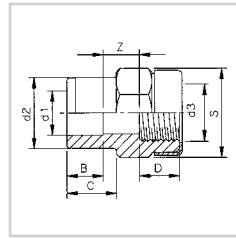
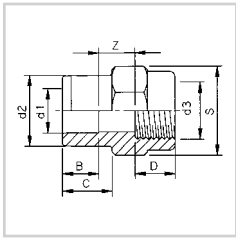

TYPE A

TYPE B

ART.CODE	d1	d2	d3	Z	B	C	D	S	TYPE	PN	QUANTITY
3.27.010	10	16	1/4" (F)	9	12	14	12	24	A	16	100
3.27.015	12	16	3/8" (F)	11	12	14	12	27	A	10	100
3.27.016	12	16	3/8" (F)	11	12	14	12	27	B	16	50
3.27.017	-	20	1/2" (F)	-	-	16	15	32	A	10	100
3.27.018	-	20	1/2" (F)	-	-	16	15	32	B	16	50
3.27.020	16	25	1/2" (F)	13.5	14	19	15	32	A	10	100
3.27.021	16	25	1/2" (F)	13.5	14	19	15	32	B	16	50
3.27.025	20	32	3/4" (F)	17	16	22	16	36	A	10	100
3.27.026	20	32	3/4" (F)	17	16	22	16	36	B	16	50
3.27.032	25	32	1" (F)	15.5	19	22	22	46	A	10	200
3.27.033	25	32	1" (F)	15.5	19	22	22	46	B	16	75
3.27.040	32	40	1 1/4" (F)	17	23	26	23	55	A	10	100
3.27.041	32	40	1 1/4" (F)	17	23	26	23	55	B	16	100
3.27.050	40	50	1 1/2" (F)	21	26	31	25	66	A	10	75
3.27.051	40	50	1 1/2" (F)	21	26	31	25	66	B	16	75
3.27.063	50	63	2" (F)	26.5	32	38	28	80	A	10	60
3.27.064	50	63	2" (F)	26.5	32	38	28	80	B	16	25
3.27.076	63	75	2 1/2" (F)	29.5	38	44	31	94	B	10	25

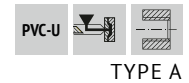

TYPE A

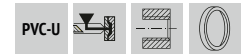

TYPE B

PVC-U METRIC

ADAPTOR SOCKET

Draadsok
Schraubmuffe
Manchon taraudé
Manicotto
Manguito transición

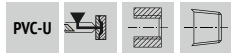

TYPE A

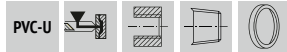

TYPE B

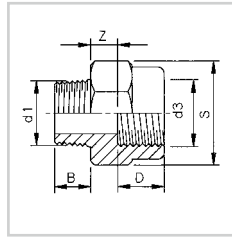

TYPE A

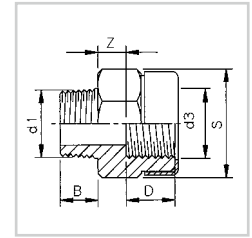

TYPE B

ART.CODE	d1	d3	Z	B	D	S	TYPE	PN	QUANTITY
3.28.010	3/8" (M)	1/4" (F)	7	12	12	24	A	16	100
3.28.015	1/4" (M)	3/8" (F)	8.5	12	12	27	A	10	100
3.28.016	1/4" (M)	3/8" (F)	8.5	12	12	27	B	16	50
3.28.017	1/2" (M)	3/8" (F)	8.5	16	12	27	A	10	100
3.28.018	1/2" (M)	3/8" (F)	8.5	16	12	27	B	16	50
3.28.020	3/8" (M)	1/2" (F)	8	12	15	32	A	10	100
3.28.021	3/8" (M)	1/2" (F)	8	12	15	32	B	16	50
3.28.021.1	1/2" (M)	1/2" (F)	8	16	15	32	A	10	50
3.28.021.2	1/2" (M)	1/2" (F)	8	16	15	32	B	16	50
3.28.022	3/4" (M)	1/2" (F)	8	17	15	32	A	10	100
3.28.023	3/4" (M)	1/2" (F)	8	17	15	32	B	16	50
3.28.025	1/2" (M)	3/4" (F)	10.5	16	16	36	A	10	100
3.28.026	1/2" (M)	3/4" (F)	10.5	16	16	36	B	16	50
3.28.026.1	3/4" (M)	3/4" (F)	10.5	17	16	36	A	10	50
3.28.026.2	3/4" (M)	3/4" (F)	10.5	17	16	36	B	16	50
3.28.027	1" (M)	3/4" (F)	10.5	21	16	36	A	10	100
3.28.028	1" (M)	3/4" (F)	10.5	21	16	36	B	16	50
3.28.032	3/4" (M)	1" (F)	12	17	22	46	A	10	100
3.28.033	3/4" (M)	1" (F)	12	17	22	46	B	16	50
3.28.034	1" (M)	1" (F)	12	21	22	46	A	10	90
3.28.035	1" (M)	1" (F)	12	21	22	46	B	16	75
3.28.036	1 1/4" (M)	1" (F)	12	23	22	46	A	10	150
3.28.037	1 1/4" (M)	1" (F)	12	23	22	46	B	16	75
3.28.040	1" (M)	1 1/4" (F)	14	21	23	55	A	10	150
3.28.041	1" (M)	1 1/4" (F)	14	21	23	55	B	16	50
3.28.042	1 1/4" (M)	1 1/4" (F)	14	23	23	55	A	10	150
3.28.043	1 1/4" (M)	1 1/4" (F)	14	23	23	55	B	16	50
3.28.044	1 1/2" (M)	1 1/4" (F)	14	23	23	55	A	10	150
3.28.045	1 1/2" (M)	1 1/4" (F)	14	23	23	55	B	16	100
3.28.050	1 1/4" (M)	1 1/2" (F)	16	23	25	66	A	10	100
3.28.051	1 1/4" (M)	1 1/2" (F)	16	23	25	66	B	16	75
3.28.052	1 1/2" (M)	1 1/2" (F)	16	23	25	66	A	10	100
3.28.053	1 1/2" (M)	1 1/2" (F)	16	23	25	66	B	16	75
3.28.063	1 1/2" (M)	2" (F)	21.5	23	28	80	A	10	50
3.28.064	1 1/2" (M)	2" (F)	21.5	23	28	80	B	16	50
3.28.065	2" (M)	2" (F)	21.5	27	28	80	A	10	50
3.28.066	2" (M)	2" (F)	21.5	27	28	80	B	16	40
3.28.076	2" (M)	2 1/2" (F)	23.5	27	31	94	B	10	45
3.28.078	2 1/2" (M)	2 1/2" (F)	23.5	31	31	94	B	10	45

REDUCING BUSH

Verlooping
Reduzierstück
Réduction courte
Riduzione curta
Reducción corta

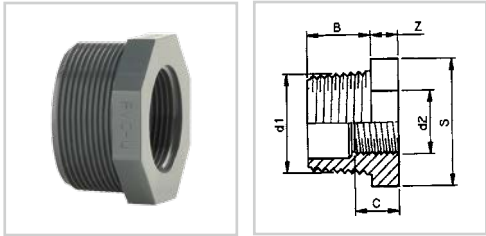

ART.CODE	d1	d2	Z	B	C	S	PN	QUANTITY
3.11.024	¾" (M)	¼" (F)	8	17	12	32	16	100
3.11.025	¾" (M)	⅜" (F)	8	17	14	32	16	100
3.11.031	1" (M)	⅜" (F)	9	21	14	36	16	100
3.11.032	1" (M)	½" (F)	9	21	16	36	16	100
3.11.039	1¼" (M)	½" (F)	10	23	16	46	16	100
3.11.040	1¼" (M)	¾" (F)	10	23	16	46	16	100
3.11.049	1½" (M)	¾" (F)	11	23	16	55	16	100
3.11.050	1½" (M)	1" (F)	11	23	22	55	16	100
3.11.062	2" (M)	1" (F)	12	27	22	65	16	100
3.11.063	2" (M)	1¼" (F)	12	27	23	65	16	100
3.11.064	2" (M)	1½" (F)	12	27	24	65	16	100
3.11.074	2½" (M)	1¼" (F)	13	31	23	80	16	50
3.11.075	2½" (M)	1½" (F)	13	31	23	80	16	50
3.11.076	2½" (M)	2" (F)	13	31	34	80	16	50
3.11.089	3" (M)	1½" (F)	16	34	23	94	16	50
3.11.090	3" (M)	2" (F)	16	34	34	94	16	50
3.11.091	3" (M)	2½" (F)	16	34	39	94	16	50

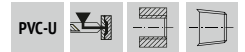

PVC-U METRIC

ADAPTOR NIPPLE

Draadeind
Gewindestück
Embout fileté
Manicotto nipplo
Manchon de transición

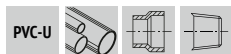

TYPE A

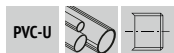

TYPE B

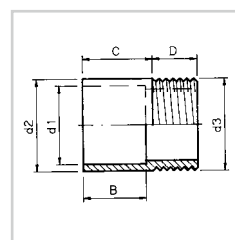
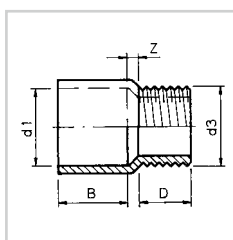

TYPE A

TYPE B

ART.CODE	d1	d2	d3	Z	B	C	D	TYPE	PN	QUANTITY
1.40.010	25	-	½" (M)	11	19	-	13	A	16	300
1.40.015	25	-	¾" (M)	10	19	-	13	A	16	300
1.40.020	25	32	1" (M)	-	19	22	19	B	16	300
1.40.025	32	-	½" (M)	17	22	-	19	A	10	400
1.40.030	32	-	¾" (M)	14	22	-	13	A	16	400
1.40.035	32	-	1" (M)	9	22	-	15	A	16	300
1.40.040	32	40	1¼" (M)	-	22	26	21	B	16	300
1.40.045	40	-	1" (M)	18	26	-	15	A	16	300
1.40.050	40	-	1¼" (M)	10	26	-	19	A	16	300
1.40.055	40	48	1½" (M)	10	26	36	21	B	16	300
1.40.060	50	-	1¼" (M)	14	31	-	21	A	16	200
1.40.065	50	-	1½" (M)	13	31	-	21	A	16	200
1.40.070	50	60	2" (M)	12	31	43	26	B	16	200
1.40.075	63	-	1¼" (M)	31	38	-	19	A	10	100
1.40.080	63	-	1½" (M)	27	38	-	21	A	16	100
1.40.085	63	-	2" (M)	16	38	-	23	A	16	100
1.40.090	63	75	2½" (M)	-	38	44	31	B	16	100
1.40.095	75	-	1¼" (M)	42	44	-	19	A	10	75
1.40.100	75	-	1½" (M)	36	44	-	21	A	10	75
1.40.105	75	-	2" (M)	26	44	-	23	A	16	75
1.40.110	75	-	2½" (M)	15	44	-	28	A	16	80
1.40.115	75	90	3" (M)	-	44	51	34	B	16	65
1.40.120	90	-	2" (M)	40	51	-	51	A	10	45
1.40.125	90	-	2½" (M)	27	51	-	28	A	16	55
1.40.130	90	-	3" (M)	18	51	-	30	A	16	36
1.40.135	90	110	4" (M)	-	51	66	33	B	16	24
1.40.140	110	-	2½" (M)	45	61	-	28	A	10	24
1.40.145	110	-	3" (M)	40	61	-	40	A	16	32
1.40.150	110	-	4" (M)	12	61	-	28	A	16	27
1.40.155	125	-	3" (M)	47	69	-	28	A	16	24
1.40.160	125	-	4" (M)	32	69	-	28	A	16	24
1.40.165	125	140	5" (M)	-	69	76	44	B	16	18
1.40.167	140	-	4" (M)	37	76	-	38	A	16	12
1.40.168	140	-	5" (M)	25	76	-	40	A	16	12
1.40.169	140	160	6" (M)	-	76	86	44	B	16	10
1.40.170	160	-	4" (M)	44	86	-	36	A	16	8
1.40.175	160	-	5" (M)	22	86	-	38	A	16	8
1.40.180	160	-	6" (M)	25	86	-	40	A	16	8
1.40.185	200	-	6" (M)	50	106	-	40	A	10	4
1.40.190	200	-	8" (M)	15	106	-	55	A	10	1

ADAPTOR NIPPLE

Draadeind
Gewindestück
Embout fileté
Manicotto nipplo
Manchon de transición

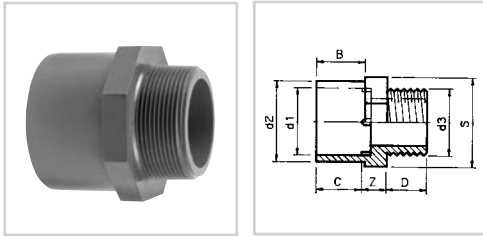

ART.CODE	d1	d2	d3	Z	B	C	D	S	PN	QUANTITY
3.15.010	10	16	¼" (M)	8	12	12	12	19	16	250
3.15.020	12	16	¼" (M)	8	12	12	12	19	16	250
4.40.110	12	16	M 11" (M)	6	12	14	9	19	16	250
4.40.380	12	16	WW ¾" (M)	6	12	14	9	19	16	250
3.15.030	16	23*	¼" (M)	5	12	14	12	27	16	250
3.15.035	16	23*	⅜" (M)	5	12	14	15	27	16	250
3.15.040	16	23*	½" (M)	5	12	14	19	27	16	250
3.15.045	20	28*	⅜" (M)	5	14	16	15	32	16	250
3.15.050	20	28*	½" (M)	5	14	16	16	32	16	250
3.15.055	20	28*	¾" (M)	6	14	16	19	32	16	250
3.15.060	25	32	½" (M)	6	19	19	16	36	16	300
3.15.065	25	32	¾" (M)	8	19	19	19	36	16	300
3.15.070	25	32	1" (M)	8	19	19	21	36	16	300
3.15.075	32	40	½" (M)	8	22	22	16	46	16	300
3.15.080	32	40	¾" (M)	10	22	22	19	46	16	300
3.15.085	32	40	1" (M)	11	22	22	21	46	16	300
3.15.090	32	40	1¼" (M)	11	22	22	23	46	16	300
3.15.092	40	50	½" (M)	11	26	26	19	55	16	225
3.15.093	40	50	¾" (M)	11	26	26	19	55	16	225
3.15.095	40	50	1" (M)	11	26	26	21	55	16	225
3.15.100	40	50	1¼" (M)	11	26	26	23	55	16	200
3.15.105	40	50	1½" (M)	11	26	26	23	55	16	175
3.15.110	50	63	1" (M)	12	31	31	21	65	16	150
3.15.115	50	63	1¼" (M)	12	31	31	23	65	16	150
3.15.120	50	63	1½" (M)	12	31	31	23	65	16	150
3.15.125	50	63	2" (M)	12	31	31	27	65	16	150
3.15.130	63	75	1¼" (M)	19	44	38	23	80	16	80
3.15.135	63	75	1½" (M)	19	44	38	23	80	16	80
3.15.140	63	75	2" (M)	19	44	38	27	80	16	80
3.15.145	63	75	2½" (M)	19	44	38	31	80	16	90
3.15.150	75	90	2" (M)	25	51	44	27	95	16	48
3.15.155	75	90	2½" (M)	25	51	44	31	95	16	48
3.15.160	75	90	3" (M)	25	51	44	33	95	16	48
3.15.165	90	110	2½" (M)	31	61	51	31	115	16	27
3.15.170	90	110	3" (M)	31	61	51	33	115	16	27
3.15.175	90	110	4" (M)	31	61	51	40	115	16	27
3.15.180	110	132*	3" (M)	25	61	61	33	138	16	20
3.15.185	110	132*	4" (M)	25	61	61	40	138	16	18



* Non-functional size

PVC-U METRIC

ADAPTOR NIPPLE

Draadeind
Gewindestück
Embout fileté
Manicotto nipplo
Manchon de transición

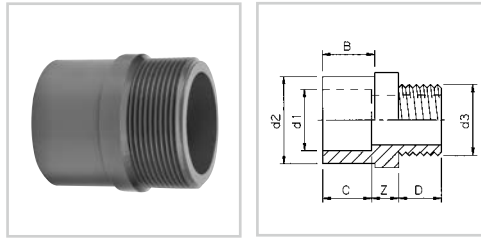

ART.CODE	d1	d2	d3	Z	B	C	D	PN	QUANTITY
3.20.030	25	32	½" (M)	6	22	19	18	10	500
3.20.045	25	32	¾" (M)	5	22	19	18	10	500
3.20.050	25	32	1" (M)	6	22	19	17	10	500
3.20.055	32	40	1" (M)	5	23	22	18	10	500
3.20.060	32	40	1¼" (M)	4	23	22	18	10	600
3.20.065	40	50	1¼" (M)	11	31	26	23	10	300
3.20.070	40	50	1½" (M)	12	31	26	23	10	275
3.20.075	50	-	1½" (M)	12	-	31	23	10	200
3.20.080	50	-	2" (M)	12	-	31	27	10	150
3.20.090	63	-	2" (M)	8	-	38	27	10	100



ADAPTOR NIPPLE

Inzetdraadeind
Gewindestück
Embout fileté
Manicotto nipplo
Manchon de transición

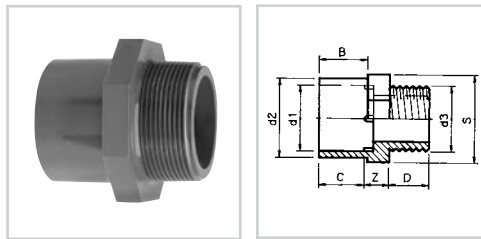

ART.CODE	d1	d2	d3	Z	B	C	S	D	PN	QUANTITY
3.30.010	-	16	¼" (M)	8	14	-	27	13	16	100
3.30.011	-	16	⅜" (M)	8	14	-	27	15	16	100
3.30.012	-	16	½" (M)	8	14	-	27	19	16	100
3.30.015	-	20	⅜" (M)	8	16	-	32	15	16	100
3.30.016	-	20	½" (M)	8	16	-	32	19	16	100
3.30.017	-	20	¾" (M)	8	16	-	32	19	16	100
3.30.020	-	25	½" (M)	9	19	-	36	19	16	100
3.30.025	-	25	¾" (M)	9	19	-	36	19	16	100
3.30.030	-	25	1" (M)	9	19	-	36	21	16	100
3.30.040	25	32	¾" (M)	10	22	19	46	19	16	100
3.30.045	25	32	1" (M)	12	22	19	46	21	16	100
3.30.046	25	32	1¼" (M)	10	22	19	46	23	16	100
3.30.050	-	40	1" (M)	11	26	-	55	21	16	100
3.30.055	-	40	1¼" (M)	11	26	-	55	23	16	100
3.30.060	-	50	1¼" (M)	12	31	-	65	23	16	100
3.30.065	-	50	1½" (M)	12	31	-	65	23	16	100
3.30.070	-	63	1¼" (M)	13	38	-	80	23	16	100
3.30.075	-	63	1½" (M)	13	38	-	80	23	16	100
3.30.080	-	63	2" (M)	13	38	-	80	27	16	100



REDUCING BUSH

Lijmring
Reduktion
Réduction courte
Bussole di riduzione
Casquillo reducción

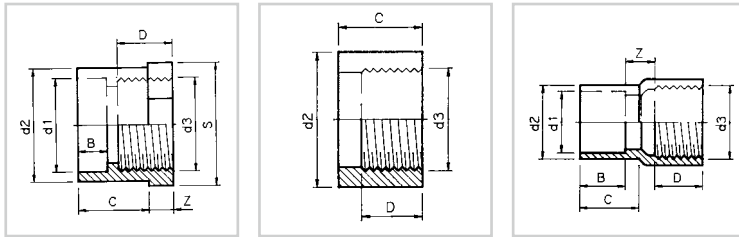

TYPE A

TYPE B

TYPE C

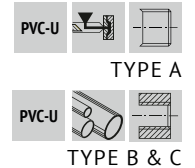

ART.CODE	d1	d2	d3	Z	B	C	S	D	TYPE	PN	QUANTITY
3.10.016	-	16	¼" (F)	6	-	14	19	14	A	16	250
3.10.020	-	20	¼" (F)	6	-	16	22	14	A	16	250
3.10.021	-	20	⅜" (F)	6	-	16	22	14	A	16	250
3.10.025	-	25	⅜" (F)	8	-	19	27	14	A	16	250
3.10.026	-	25	½" (F)	8	-	19	27	17	A	16	250
3.10.032	-	32	½" (F)	8	-	22	36	17	A	16	250
3.10.033	-	32	¾" (F)	8	-	22	36	19	A	16	250
3.10.039	-	40	½" (F)	11	-	26	46	17	A	16	200
3.10.040	-	40	¾" (F)	11	-	26	46	19	A	16	100
3.10.041	-	40	1" (F)	11	-	26	46	21	A	16	100
3.10.048	-	50	½" (F)	12	-	31	55	17	A	16	100
3.10.049	-	50	¾" (F)	12	-	31	55	19	A	16	100
3.10.050	-	50	1" (F)	12	-	31	55	21	A	16	100
3.10.051	-	50	1¼" (F)	12	-	31	55	23	A	16	100
3.10.060	-	63	½" (F)	13	-	38	65	17	A	16	100
3.10.061	-	63	¾" (F)	13	-	38	65	19	A	16	100
3.10.062	-	63	1" (F)	13	-	38	65	21	A	16	100
3.10.063	-	63	1¼" (F)	13	-	38	65	23	A	16	100
3.10.064	-	63	1½" (F)	13	-	38	65	23	A	16	100
3.10.074	-	75	1¼" (F)	13	-	44	80	23	A	16	50
3.10.075	-	75	1½" (F)	13	-	44	80	23	A	16	50
3.10.076	-	75	2" (F)	13	-	44	80	29	A	16	50
3.10.090	75	90	2" (F)	20	44	51	95	25	A	16	50
3.10.091	-	90	2½" (F)	20	-	51	95	31	A	16	50
3.10.092	75	90	3" (F)	18	44	51	-	35	C	10	50
3.10.110	90	110	2" (F)	22	-	61	115	29	A	16	25
3.10.111	90	110	2½" (F)	22	-	61	115	31	A	16	25
3.10.112	-	110	3" (F)	22	-	61	115	34	A	16	25
3.10.113	-	110	4" (F)	30	-	61	-	40	C	10	25
3.10.125	-	125	3" (F)	25	-	69	138	34	A	10	25
3.10.126	-	125	4" (F)	25	-	69	138	34	A	10	25
3.10.160	-	160	5" (F)	-	-	86	-	44	B	16	8
3.10.200	-	200	6" (F)	-	-	106	-	44	B	16	10

PVC-U METRIC

REDUCING BUSH

Lijmring
Reduktion
Réduction courte
Bussole di riduzione
Casquillo reducción

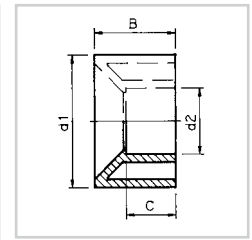
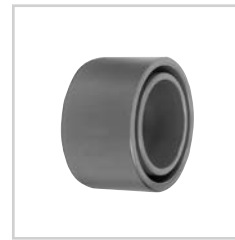
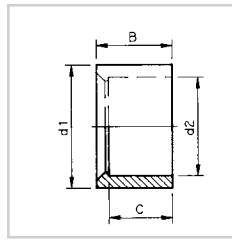

TYPE A

TYPE B

ART.CODE	d1	d2	B	C	TYPE	PN	QUANTITY
3.05.016	16	12	14	12	A	16	250
3.05.018	20	10	16	12	A	16	250
3.05.019	20	12	16	12	A	16	250
3.05.020	20	16	16	14	A	16	250
3.05.024	25	12	19	12	B	16	250
3.05.025	25	16	19	14	A	16	250
3.05.026	25	20	19	16	A	16	250
3.05.032	32	16	22	14	B	16	250
3.05.033	32	20	22	16	B	16	250
3.05.034	32	25	22	19	A	16	250
3.05.040	40	16	26	14	B	16	200
3.05.041	40	20	26	16	B	16	200
3.05.042	40	25	26	19	B	16	200
3.05.043	40	32	26	22	A	16	200
3.05.050	50	20	31	16	B	16	200
3.05.051	50	25	31	19	B	16	200
3.05.052	50	32	31	22	B	16	200
3.05.053	50	40	31	26	A	16	200
3.05.063	63	25	38	19	B	16	200
3.05.064	63	32	38	22	B	16	200
3.05.065	63	40	38	26	B	16	200
3.05.066	63	50	38	31	A	16	200
3.05.075	75	32	44	22	B	16	100
3.05.076	75	40	44	26	B	16	100
3.05.077	75	50	44	31	B	16	100
3.05.078	75	63	44	38	A	16	100
3.05.090	90	50	51	31	B	16	50
3.05.091	90	63	51	38	B	16	50
3.05.092	90	75	51	44	A	16	50
3.05.095	90	80	51	46	A	16	50
3.05.110	110	50	61	31	B	16	25
3.05.111	110	63	61	38	B	16	25
3.05.112	110	75	61	44	B	16	25
3.05.113	110	90	61	51	A	16	25
3.05.115	110	100	61	56	A	16	25
3.05.125	125	75	69	44	B	16	24
3.05.126	125	90	69	51	B	16	24
3.05.127	125	110	69	61	A	16	24
3.05.140	140	75	76	44	B	16	15
3.05.141	140	90	76	51	B	16	15

REDUCING BUSH

Lijmring
Reduktion
Réduction courte
Bussole di riduzione
Casquillo reducción

ART.CODE	d1	d2	B	C	TYPE	PN	QUANTITY
3.05.142	140	110	76	61	B	16	15
3.05.143	140	125	76	69	A	16	15
3.05.160	160	90	86	51	B	16	8
3.05.161	160	110	86	61	B	16	8
3.05.162	160	125	86	69	A	16	8
3.05.163	160	140	86	76	A	16	8
3.05.197	200	110	106	61	B	10	10
3.05.198	200	125	106	69	B	10	10
3.05.199	200	140	106	76	B	10	10
3.05.200	200	160	106	86	A	10	10
3.05.221	225	125	119	69	B	10	3
3.05.222	225	110	119	61	B	10	3
3.05.223	225	140	119	76	B	10	3
3.05.224	225	160	119	86	B	10	3
3.05.225	225	200	119	106	A	10	3
3.05.247	250	125	131	69	B	10	3
3.05.248	250	140	131	76	B	10	3
3.05.249	250	160	131	86	B	10	3
3.05.250	250	200	131	106	A	10	3
3.05.251	250	225	131	119	A	10	3
3.05.276	280	140	146	76	B	10	1
3.05.277	280	160	146	86	B	10	1
3.05.278	280	200	146	106	B	10	1
3.05.279	280	225	146	119	A	10	1
3.05.280	280	250	146	131	A	10	1
3.05.313	315	160	164	86	B	10	1
3.05.314	315	200	164	106	B	10	1
3.05.315	315	225	164	119	B	10	1
3.05.316	315	250	164	131	A	10	1
3.05.317	315	280	164	146	A	10	1
3.05.350	355	315	184	164	A	6	1
3.05.400	400	250	206	131	B	6	1
3.05.402	400	280	206	146	B	6	1
3.05.403	400	315	206	164	A	6	1
3.05.405	400	355	206	184	A	6	1

PVC-U METRIC

NIPPLE

Draadnippel
Doppelnippel
Mamelon fileté
Niplo
Nipple



TYPE A

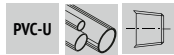

TYPE B

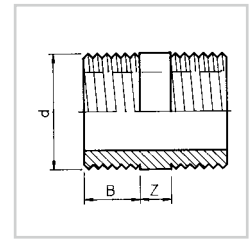
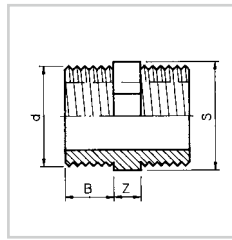
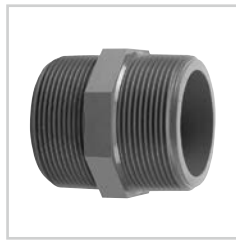

TYPE A

TYPE B

ART.CODE	d	Z	B	S	TYPE	PN	QUANTITY
3.35.035	¼" (M)	8	12	19	A	16	100
3.35.045	⅜" (M)	8	15	24	A	16	100
3.35.055	½" (M)	8	17	27	A	16	100
3.35.065	¾" (M)	8	17	32	A	16	100
3.35.075	1" (M)	9	21	36	A	16	100
3.35.085	1¼" (M)	10	23	46	A	16	100
3.35.095	1½" (M)	11	23	55	A	16	100
3.35.105	2" (M)	12	27	65	A	16	100
1.50.025	2½" (M)	16	27	-	B	16	25
1.50.030	3" (M)	25	27	-	B	16	10
1.50.040	4" (M)	16	33	-	B	16	10
1.50.050	5" (M)	16	46	-	B	16	10

NIPPLE

Draadnippel
Doppelnippel
Mamelon fileté
Niplo
Nipple

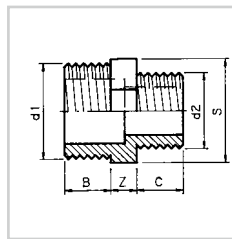
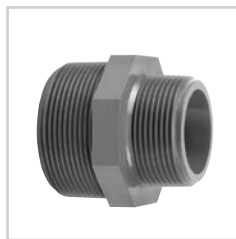

ART.CODE	d1	d2	Z	B	C	S	PN	QUANTITY
3.35.040	⅜" (M)	¼" (M)	8	15	13	24	16	100
3.35.050	½" (M)	⅜" (M)	8	17	15	27	16	100
3.35.060	¾" (M)	½" (M)	8	19	17	32	16	100
3.35.070	1" (M)	¾" (M)	9	21	19	36	16	100
3.35.080	1¼" (M)	1" (M)	9	23	21	46	16	100
3.35.090	1½" (M)	1¼" (M)	11	23	23	55	16	100
3.35.100	2" (M)	1½" (M)	12	27	23	65	16	100

PVC-U METRIC

SCREWCAP

Draadkap
Schraubkappe
Bouchon taraudé
Calotta a filetto
Tapon rosco hembra

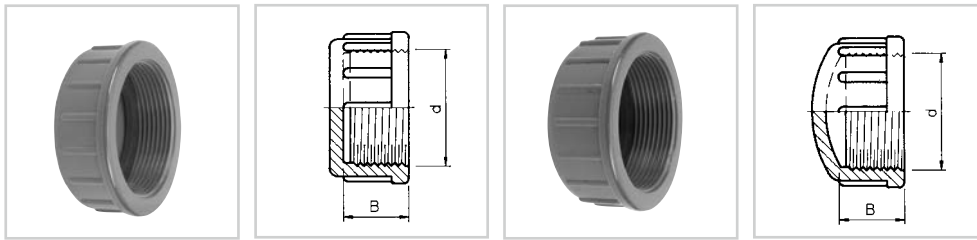

TYPE A

TYPE B

ART.CODE	d	B	TYPE	PN	QUANTITY
3.40.010	3/8" (F)	13	A	10	250 (5x50)
3.40.020	1/2" (F)	14	A	10	500 (10x50)
3.40.030	3/4" (F)	16	A	10	400 (8x50)
3.40.040	1" (F)	17	A	10	500 (10x50)
3.40.050	1 1/4" (F)	19	A	10	500 (10x50)
3.40.060	1 1/2" (F)	23	B	10	300
3.40.062	1 1/2" (F)	23	A	10	300
3.40.070	2" (F)	24	B	10	150
3.40.072	2" (F)	24	A	10	150
3.40.075	2 1/4" (F)	25	A	10	25
3.40.080	2 1/2" (F)	29	B	10	100
3.40.082	2 1/2" (F)	29	A	10	100
3.40.085	2 3/4" (F)	29	A	10	25
3.40.090	3" (F)	31	B	10	50
3.40.092	3" (F)	31	A	10	50
3.40.100	4" (F)	34	B	6	10
3.40.102	4" (F)	34	A	6	10

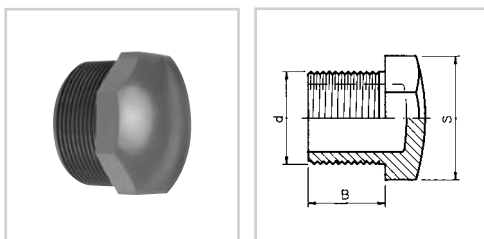
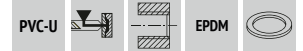

PLUG

Draadstop
Gewindestopfen
Bouchon fileté
Tappo
Tapon rosco macho

ART.CODE	d	B	S	PN	QUANTITY
3.45.025	1/4" (M)	12	17	16	100
3.45.030	3/8" (M)	14	22	16	100
3.45.040	1/2" (M)	18	27	16	100
3.45.045	3/4" (M)	19	32	16	100
3.45.050	1" (M)	22	36	16	100
3.45.055	1 1/4" (M)	24	46	16	100
3.45.060	1 1/2" (M)	24	55	16	100
3.45.065	2" (M)	27	65	16	100
3.45.070	2 1/2" (M)	31	94	10	25
3.45.075	3" (M)	34	114	10	25
3.45.080	4" (M)	40	138	10	25



PVC-U METRIC

CAP

Lijmkap
Klebekappe
Bouchon à coller
Calotta
Tapón

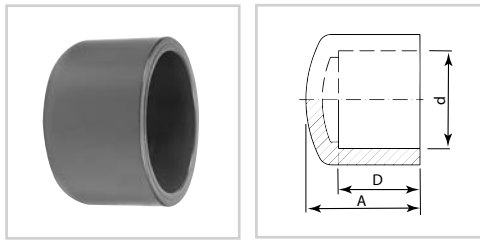

ART.CODE	d	A	B	PN	QUANTITY
3.55.010	10	17	12	16	250
3.55.012	12	18	12	16	250
3.55.016	16	24	14	16	250
3.55.020	20	25	16	16	250
3.55.025	25	29	19	16	250
3.55.032	32	33	22	16	175
3.55.040	40	40	26	16	100
3.55.050	50	47	31	16	200
3.55.063	63	57	38	16	115
3.55.075	75	67	44	16	70
3.55.090	90	77	51	16	45
3.55.110	110	95	61	16	24
3.55.125	125	103	69	16	15
3.55.140	140	118	76	16	15
3.55.160	160	131	86	16	8
3.55.200	200	170	107	10	3
3.55.225	225	185	119	10	2
3.55.250	250	205	132	10	2
3.55.280	280	230	147	10	1
3.55.315	315	255	165	10	1

HOSE NOZZLE

Slangpilaar
Schlauchtülle
Embout cannelé
Portagomma
Conexión manguera

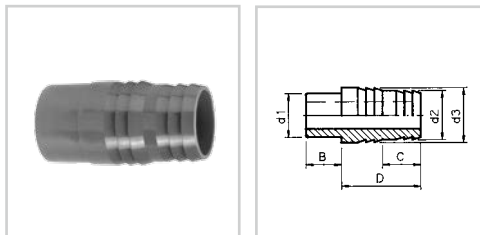

ART.CODE	d1	d2	d3	B	C	D	QUANTITY
3.57.010	10	10	10	12	16	31	100
3.57.012	12	12	14	12	16	36	100
3.57.016	16	16	18	14	18	40	100
3.57.020	20	20	22	16	20	44	100
3.57.025	25	25	28	19	24	54	100
3.57.032	32	31	34	22	28	63	100
3.57.040	40	40	43	26	32	72	100
3.57.050	50	50	53	31	35	80	100
3.57.063	63	60	66	38	40	90	50

PVC-U METRIC

HOSE NOZZLE

Slangpilaar
Schlauchtülle
Embout cannelé
Portagomma
Conexión manguera

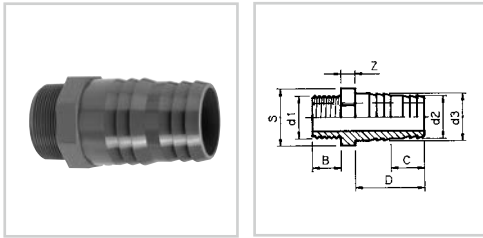

ART.CODE	d1	d2	d3	Z	B	C	D	S	QUANTITY
3.57.013	¼" (M)	12	14	6	11	16	36	15	100
3.57.017	⅜" (M)	16	18	7	12	18	40	19	100
3.57.021	½" (M)	20	22	8	15	20	44	24	100
3.57.026	¾" (M)	25	28	8	16	24	54	30	100
3.57.033	1" (M)	31	34	9	18	28	63	35	100
3.57.041	1¼" (M)	40	43	13	21	32	72	46	100
3.57.051	1½" (M)	50	53	14	21	35	80	55	100
3.57.064	2" (M)	60	66	16	26	40	90	70	50



HOSE NOZZLE

Slangpilaar
Schlauchtülle
Embout cannelé
Portagomma
Conexión manguera

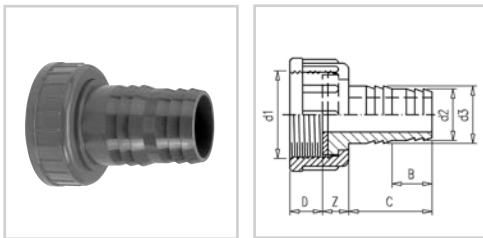

ART.CODE	d1	d2	d3	Z	B	C	D	QUANTITY
3.57.018	¾" (F)	16	18	17	18	40	11	50
3.57.022	1" (F)	20	22	17	20	44	11	50
3.57.027	1¼" (F)	25	28	17	24	54	13	50
3.57.034	1½" (F)	31	34	20	28	63	13	50
3.57.042	2" (F)	40	43	20	32	72	15	50
3.57.052	2¼" (F)	50	53	23	35	80	16	50
3.57.065	2¾" (F)	60	66	23	40	90	21	25

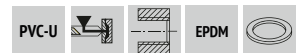

PVC-U METRIC

UNION NUT (PARTS)

for injection moulded
adaptor union and hose
nozzle

Wartelmoer voor spuitgietskoppeling
en slangpilaar

Überwurfmutter für Spritzguss

Verschraubung und Schlauchtülle

Ecrou de raccord pour raccord union
et embout cannelé

Chiera per iniezione bocchettone e
portagomma

Tuerca enlace para unión y conexión
manguera

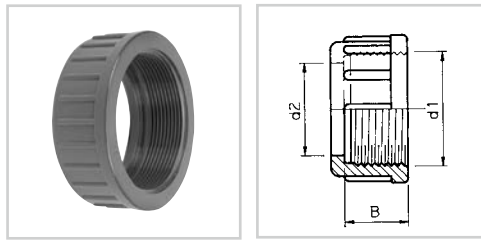

ART.CODE	Dia	d1	d2	B	QUANTITY
8.20.016	16	3/4" (F)	22	16	50
8.20.020	20	1" (F)	27	16	50
8.20.025	25	1 1/4" (F)	36	19	50
8.20.032	32	1 1/2" (F)	41	19	50
8.20.040	40	2" (F)	53	22	25
8.20.050	50	2 1/4" (F)	60	24	25
8.20.063	63	2 3/4" (F)	75	29	25

PVC-U

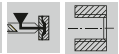

UNION WASHER (PARTS)

for hose nozzle

Rubber afdichtring voor slangpilaar

Gummiring für Schlauchtülle

Joint caoutchouc pour embout cannelé

Guarnizione di gomma per portagomma

Junta cuacho para conexión manguera

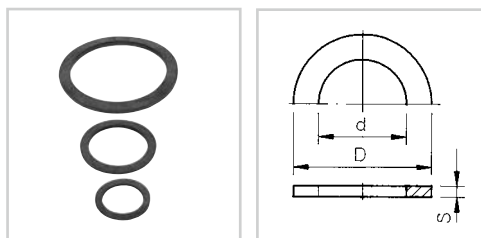

ART.CODE	Dia	d	D	S	QUANTITY
8.03.016	16	11	23	2	100
8.03.020	20	15	29	2	100
8.03.025	25	19	37	2	100
8.03.032	32	24	43	3	100
8.03.040	40	32	55	3	100
8.03.050	50	40	61	3	100
8.03.063	63	50	77	3	50

EPDM

BACKING FLANGE

Flens
Flansch
Bride
Flangia
Brida

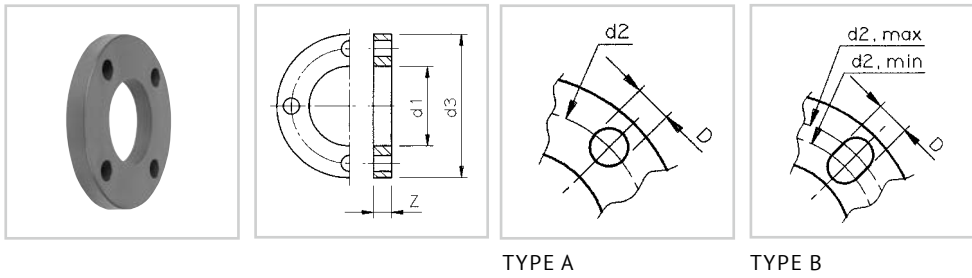

ART.CODE	Dia	DN	d1	d2	d3	Z	NXD	NORM	TYPE	QUANTITY
3.72.016	16	10	23	60	90	10	4x14	•	A	50
3.72.020	20	15	28	60.5/63	95	11	4x16	••	B	50
3.72.025	25	20	34	70/73	105	12	4x16	••	B	50
3.72.032	32	25	42	79/83	115	14	4x16	••	B	50
3.72.040	40	32	51	91/100	140	15	4x18	••	B	30
3.72.050	50	40	62	101/110	150	16	4x18	••	B	75
3.72.063	63	50	78	120.5/124	165	18	4x18	••	B	50
3.72.075	75	65	92	145	185	19	4x18	•	A	30
3.72.090	90	80	110	160	200	20	8x18	•	A	25
3.72.110	110	100	133	180	220	22	8x18	•	A	15
3.72.125	125	100	150	190	235	26	8x18		A	15
3.72.140	140	125	167	210	250	26	8x18	•	A	15
3.72.160	160	150	190	240	285	28	8x22	•	A	10
3.72.200	200	175	235	270	315	36	8x22	•••	A	5
3.72.225	225	200	251	295	340	36	8x22	•	A	5
3.72.250	250	225	277	325	370	36	8x22	•••	A	5
3.72.280	280	250	309	350	395	36	12x22	•	A	1
3.72.315	315	300	345	400	445	36	12x22	•	A	1
3.72.355	355	350	388	460	505	38	16x22	•	A	1
3.72.400	400	400	442	515	565	42	16x26	•	A	1

Connecting dimension according to...
Bevestigingsmaat volgens...
Anschlußmasse zufolge...

Mesure de assujettir suivant...
Misura di attaccare secondo...
Medida de sujetar según...

- ISO/DIN 2501 PN10
- ISO/DIN 2501 PN10 / ANSI B16.5
- ISO 2536 PN10

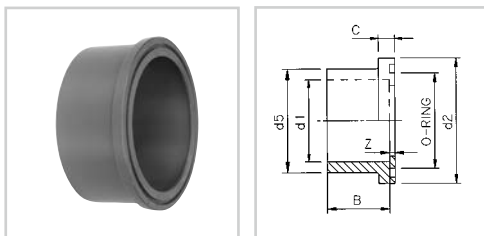

ART.CODE	d1	d2	d5	Z	B	C	O-RING & T-RING	QUANTITY
3.72.202	200	248	232	7	106	19	215.3x7	3
3.72.227	225	273	248	7	119	23	240.7x7	3
3.72.252	250	303	274	9	131	23	266.0x7	4
3.72.282	280	328	305	9	146	26	295.0x10	2
3.72.317	315	378	342	10	164	31	330.0x10	1

FLANGE ADAPTOR (O-RING)

Kraagbus (O-ring)
Bundbusche (O-Ring)
Collet (joint torique)
Collage (O-ring)
Portabrida (junta)



PVC-U METRIC

FLANGE ADAPTOR

Kraagbus
Bundbusche
Collet
Collare
Portabrida

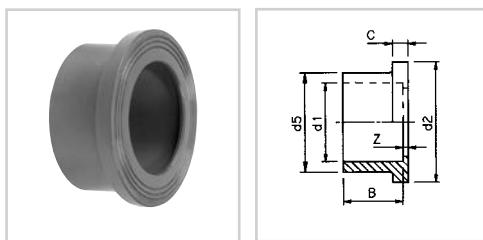

ART.CODE	d1	DN	d2	d5	Z	B	C	QUANTITY
3.72.017	16	10	29	22	3	14	6	100
3.72.021	20	15	34	27	3	16	6	100
3.72.026	25	20	41	33	3	19	7	100
3.72.033	32	25	50	41	3	22	7	100
3.72.041	40	32	60	50	3	26	8	100
3.72.051	50	40	72	61	3	31	8	150
3.72.064	63	50	90	77	3	38	9	75
3.72.076	75	65	106	91	3	44	10	50
3.72.091	90	80	125	108	5	51	11	40
3.72.111	110	100	150	131	7	61	12	25
3.72.126	125	100	170	148	7	69	13	10
3.72.141	140	125	188	165	5	76	14	10
3.72.161	160	150	212	188	5	86	18	10
3.72.201	200	200	248	232	7	106	19	3
3.72.203*	200	200	248	224	7	106	19	3
3.72.226	225	200	273	248	7	119	23	3
3.72.251	250	225	303	274	7	131	23	4
3.72.281	280	250	328	306	9	146	26	2
3.72.316	315	300	378	342	10	164	31	1
3.72.356	355	350	430	384	10	184	32	1
3.72.401	400	400	484	438	10	206	34	1

* Suitable for combination with PP-V flange



FLANGE ADAPTOR

Kraagbus
Bundbusche
Collet
Collare
Portabrida

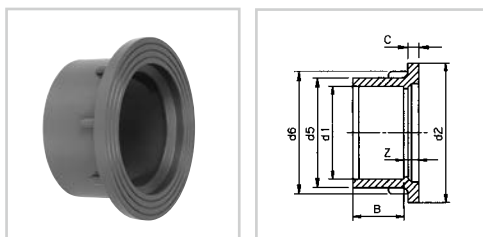

ART.CODE	d1	d2	d5	d6	Z	B	C	QUANTITY
3.72.068	63	106 (75)	77	91	12	38	10	50
3.72.130	125	188 (140)	148	165	21	69	14	10
3.72.205	200	273 (225)	228	248	34	106	22	3
3.72.255	250	328 (280)	280	306	35	131	25	4

Reducing flange adaptor
Verloop kraagbus
Bundbuchse reduziert
Collet réduit
Collare ridotto
Portabrida reducida



FIXED FLANGE

Lijmflens
Klebeflansch
Bride fixe
Flangia fissa
Brida fija

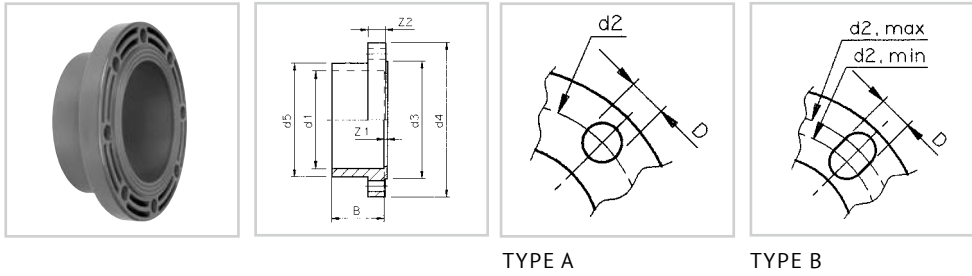

ART.CODE	d1	d2	d3	d4	d5	Z1	Z2	B	NXD	NORM	TYPE	QUANTITY
3.73.075	75	139.5/144	106	185	91	3	19	44	4x19	••	B	24
3.73.090	90	152.5/159	125	200	108	5	20	51	8x19	••	B	15
3.73.110	110	181/190.5	150	220	131	5	22	61	8x19	••	B	8
3.73.125	125	190	166	235	148	5	26	69	8x18		A	8
3.73.140	140	215	184	250	165	5	26	76	8x23	••	A	6
3.73.160	160	240	209	285	188	5	28	86	8x24	••	A	4
3.73.200	200	270	248	315	232	5	36	106	8x22	•••	A	3
3.73.225	225	295	260	340	248	7	36	119	8x22	•	A	3
3.73.250	250	325	303	370	274	7	36	131	8x22	•••	A	2
3.73.280	280	350	328	395	306	9	36	146	12x22	•	A	2
3.73.315	315	400	378	445	342	7	36	164	12x22	•	A	1

Connecting dimension according to...
Bevestigingsmaat volgens...
Anschlußmasse zufolge...

Mesure de assujettir suivant...
Misura di attaccare secondo...
Medida de sujetar según...

- ISO/DIN 2501 PN10
- ISO/DIN 2501 PN10 / ANSI B16.5
- ISO 2536 PN10

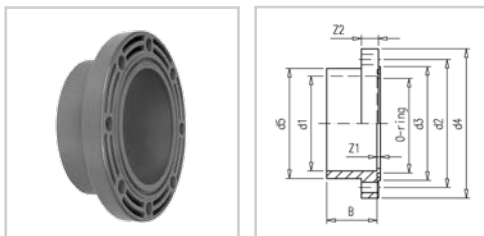

ART.CODE	d1	d2	d3	d4	d5	Z1	Z2	B	O- & T-RING	NxD	NORM	QUANTITY
3.73.201	200	270	248	315	232	7	36	106	215.3x7	8x22	••	3
3.73.226	225	295	273	340	248	7	36	119	240.7x7	8x22	•	3
3.73.251	250	325	303	370	274	9	36	131	266.0x7	8x22	••	2
3.73.281	280	350	328	395	306	9	36	146	295.0x10	12x22	•	2
3.73.316	315	400	378	445	342	10	36	164	330.0x10	12x22	•	1

Connecting dimension according to...
Bevestigingsmaat volgens...
Anschlußmasse zufolge...

Mesure de assujettir suivant...
Misura di attaccare secondo...
Medida de sujetar según...

- ISO/DIN 2501 PN10
- ISO 2536 PN10

FIXED FLANGE (O-RING)

Lijmflens (O-ring)
Klebeflansch (O-Ring)
Bride fixe (joint torique)
Flangia fissa (O-ring)
Brida fija (junta)



PVC-U METRIC

BLANK FLANGE

Blindflens
Blindflansch
Bride pleine
Flangia cieca
Brida ciega

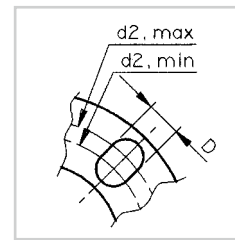
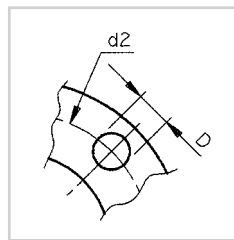
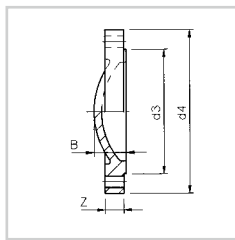

TYPE A

TYPE B

ART.CODE	Dia	DN	d2	d3	d4	Z	B	NxD	NORM	TYPE	QUANTITY
3.74.016	16	10	60	29	90	10	13.5	4x14	•	A	50
3.74.020	20	15	60.5/63	34	95	11	14.5	4x16	••	B	75
3.74.025	25	20	70/73	41	105	12	16	4x16	••	B	50
3.74.032	32	25	79/83	50	115	14	19	4x16	••	B	50
3.74.040	40	32	91/100	61	140	15	20	4x18	••	B	30
3.74.050	50	40	101/110	74	150	16	22	4x18	••	B	40
3.74.063	63	50	120.5/124	91	165	18	24.5	4x18	••	B	15
3.74.075	75	65	139.5/144	106	185	19	26.5	4x19	••	B	14
3.74.090	90	80	152.5/159	125	200	20	30	8x19	••	B	15
3.74.110	110	100	181/190.5	150	220	22	34.5	8x19	••	B	15
3.74.125	125	100	190	166	235	26	38.5	8x18		A	10
3.74.140	140	125	215	184	250	26	39	8x23	••	A	10
3.74.160	160	150	240	209	285	28	43.5	8x24	••	A	6
3.74.200	200	175	270	248	315	36	63	8x22	•••	A	5
3.74.225	225	200	295	260	340	36	63	8x22	•	A	5
3.74.250	250	225	325	303	370	36	63	8x22	•••	A	5
3.74.280	280	250	350	328	395	36	65	12x22	•	A	1
3.74.315	315	300	400	378	445	36	65	12x22	•	A	1
3.74.355	355	350	460	430	505	38	67	16x22	•	A	1
3.74.400	400	400	515	482	565	42	71	16x26	•	A	1

Connecting dimension according to...
Bevestigingsmaat volgens...
Anschlußmasse zufolge...

Mesure de assujettir suivant...
Misura di attaccare secondo...
Medida de sujetar según...

- ISO/DIN 2501 PN10
- ISO/DIN 2501 PN10 / ANSI B16.5
- ISO 2536 PN10

PP-V FLANGE

PP-V flens
PP-V flansch
PP-V bride
Flangia PP-V
PP-V brida

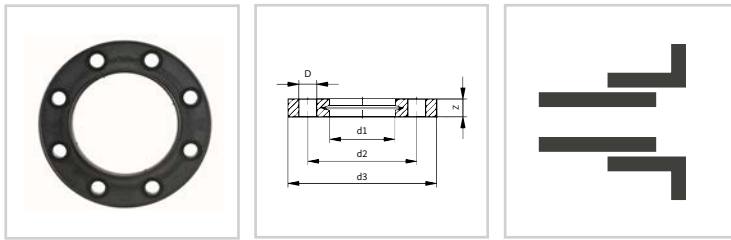

ART.CODE	Dia	DN	d1	d2	d3	Z	NxD	PN	QUANTITY
9.72.020*	20	15	28	65	95	16	4x14	16	1
9.72.025*	25	20	34	75	105	17	4x14	16	1
9.72.032*	32	25	42	85	115	18	4x14	16	1
9.72.040*	40	32	51	100	140	20	4x18	16	1
9.72.050*	50	40	62	110	150	22	4x18	16	1
9.72.063*	63	50	78	125	165	24	4x18	16	1
9.72.075*	75	65	92	145	185	26	4x18	16	1
9.72.090	90	80	110	160	200	27	8x18	16	1
9.72.110	110	100	133	180	220	28	8x18	16	1
9.72.140	140	125	167	210	250	30	8x18	16	1
9.72.160	160	150	190	241	285	32	8x22	16	1
9.72.200	200	200	226	297	340	34	8x22	16	1
9.72.225	225	200	250	297	340	34	8x22	16	1
9.72.250	250	250	277	350	395	38	8x22	16	1
9.72.280	280	250	310	350	395	38	12x22	16	1
9.72.315	315	300	348	400	445	42	12x22	16	1
9.72.355	355	350	388	460	515	46	16x22	10	1
9.72.400	400	400	442	515	574	50	16x26	10	1



- full-plastic flange: polypropylene glass-fibre reinforced (30%)
- V-groove to ensure an evenly distribution of the force when mounting
- connecting dimension: ISO 7005, EN 1092, DIN 2501
- bolt circle PN10
- suitable for socket- and butt fusion systems
- UV-resistant
- high chemical resistance

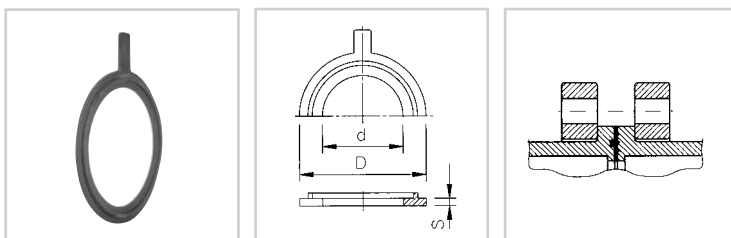

Sealing with T-Ring
Verbinding met T-Ring
Dichtung mit T-Ring
Joint avec joint T
Tenuta con T-ring
Sellado con junta T

T-RING FOR FLANGE ADAPTOR

T-Ring voor kraagbus
T-Ring für Flange Adaptor
Joint T pour collet
T-Ring per collare
Junta T para portabrida

ART.CODE	Dia	d	D	S	T-RING	QUANTITY
8.04.201	200	192	248	4	215.3x7	10
8.04.226	225	217	273	4	240.7x7	10
8.04.251	250	240	303	4	266.0x7	10
8.04.281	280	268	328	5	295.0x10	10
8.04.316	315	300	378	5	330.0x10	10

EPDM

RUBBER WASHER FOR FLANGE ADAPTOR

Rubber afdichter voor kraagbus
Gummiring für Bundbuchse
Joint caoutchouc pour collet
Guarnizione di gomma per collare
Junta caucho para portabrida

EPDM

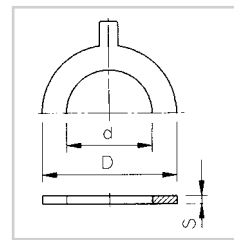
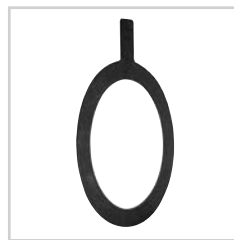
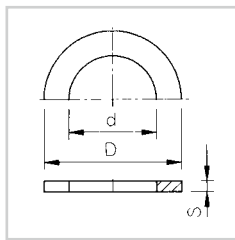
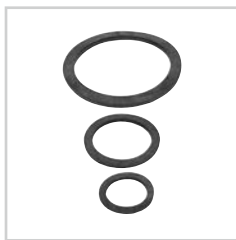

TYPE A

TYPE B

ART.CODE	Dia	d	D	S	TYPE	QUANTITY
8.04.016	16	14	27	2	A	100
8.04.020	20	18	32	2	A	100
8.04.025	25	22	39	2	A	100
8.04.032	32	28	48	2	A	100
8.04.040	40	35	59	3	A	100
8.04.050	50	45	71	3	A	150
8.04.063	63	60	88	3	A	75
8.04.075	75	70	104	3	A	50
8.04.090	90	85	123	3	A	40
8.04.110	110	105	148	4	A	25
8.04.125	125	120	168	4	A	10
8.04.140	140	135	186	4	A	10
8.04.160	160	155	211	4	A	10
8.04.200	200	192	248	4	B	10
8.04.225	225	217	273	4	B	10
8.04.250	250	240	303	4	B	10
8.04.280	280	268	328	5	B	10
8.04.315	315	300	378	5	B	10
8.04.355	355	340	430	5	A	10
8.04.400	400	385	482	5	A	10

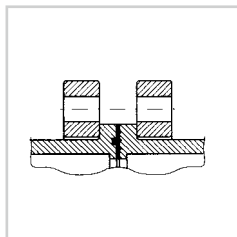

Sealing with flat ring
Verbinding met vlakke ring
Dichtung mit flachem ring
Joint avec joint plat
Tenuta con guarnizione piana
Sellado con junta

O-RING FOR FLANGE ADAPTOR

O-Ring voor kraagbus
O-Ring für Bundbuchse
Joint Torique pour collet
O-Ring per collare
Junta torica para portabrida

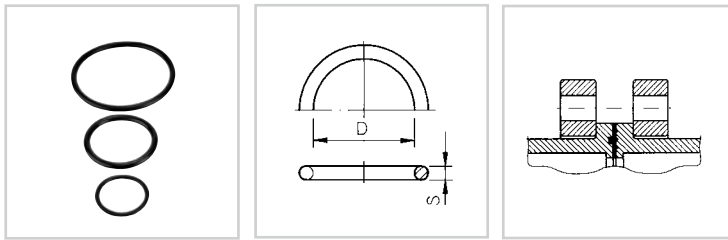

Sealing with O-Ring
Verbinding met O-Ring
Dichtung mit O-Ring
Joint avec joint torique
Tenuta con O-Ring
Sellado con junta torica

ART.CODE	Dia	D	S	QUANTITY
8.06.200	200	215.30	7.00	10
8.06.225	225	240.70	7.00	10
8.06.250	250	266.00	7.00	10
8.06.280	280	295.00	10.00	10
8.06.315	315	330.00	10.00	10

EPDM

ADAPTOR UNION

Spuitgietskoppeling
Verschraubung
Raccord union
Bocchettone
Enlace de unión

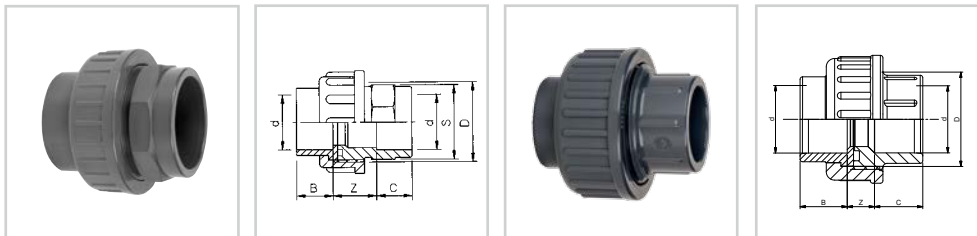

TYPE A

TYPE B

ART.CODE	d	Z	B	C	D	S	PN	TYPE	QUANTITY
3.60.010	10	22	12	12	5/8"	23	16	A	200
3.60.012	12	22	12	12	5/8"	23	16	A	200
3.60.016	16	23	14	14	3/4"	25	16	A	200
3.60.019	20	14	16	16	1"	-	16	B	100
3.60.020	20	25	16	16	1"	30	16	A	100
3.60.024	25	14	19	19	1 1/4"	-	16	B	60
3.60.025	25	23	19	19	1 1/4"	36	16	A	60
3.60.031	32	14	22	22	1 1/2"	-	16	B	150
3.60.032	32	24	22	22	1 1/2"	44	16	A	150
3.60.039	40	16	26	26	2"	-	16	B	100
3.60.040	40	23	26	26	2"	54	16	A	100
3.60.049	50	18	31	31	2 1/4"	-	16	B	60
3.60.050	50	23	31	31	2 1/4"	64	16	A	60
3.60.062	63	22	38	38	2 3/4"	-	16	B	45
3.60.063	63	20	38	38	2 3/4"	80	16	A	45
3.60.075	75	28	44	44	ZGTD	94	10	A	25
3.60.090	90	34	51	51	ZGTD	114	10	A	15
3.60.110	110	36	61	61	ZGTD	138	10	A	10

PVC-U



EPDM

PVC-U METRIC

ADAPTOR UNION

Spuitgietskoppeling
 Verschraubung
 Raccord union
 Bocchettone
 Enlace de unión

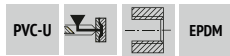

TYPE A

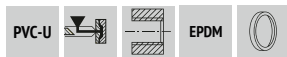

TYPE B

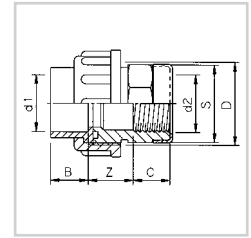
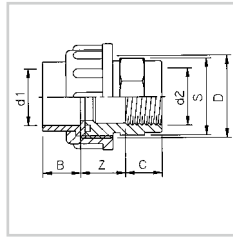

TYPE A

TYPE B

ART.CODE	d1	d2	Z	B	C	D	S	TYPE	PN	QUANTITY
3.65.010	10	¼" (F)	22	12	12	⅝"	23	A	16	100
3.65.012	12	¼" (F)	22	12	12	⅝"	23	A	16	100
3.65.016	16	⅜" (F)	25	14	12	¾"	25	A	10	100
3.65.017	16	⅜" (F)	25	14	12	¾"	25	B	16	100
3.65.020	20	½" (F)	25	16	16	1"	30	A	10	100
3.65.021	20	½" (F)	25	16	16	1"	30	B	16	100
3.65.025	25	¾" (F)	25	19	17	1¼"	36	A	10	60
3.65.026	25	¾" (F)	25	19	17	1¼"	36	B	16	60
3.65.032	32	1" (F)	25	22	21	1½"	44	A	10	100
3.65.033	32	1" (F)	25	22	21	1½"	44	B	16	100
3.65.040	40	1¼" (F)	26	26	23	2"	54	A	10	80
3.65.041	40	1¼" (F)	26	26	23	2"	54	B	16	80
3.65.050	50	1½" (F)	31	31	23	2¼"	64	A	10	60
3.65.051	50	1½" (F)	31	31	23	2¼"	64	B	16	60
3.65.063	63	2" (F)	31	38	27	2¾"	80	A	10	45
3.65.064	63	2" (F)	31	38	27	2¾"	80	B	16	45
3.65.075	75	2½" (F)	41	44	30	ZGTD	94	B	10	10
3.65.090	90	3" (F)	51	51	34	ZGTD	114	B	10	10
3.65.110	110	4" (F)	55	61	41	ZGTD	138	B	10	10

ADAPTOR UNION WITH O-RING

Koppeling met O-ring
 (zwembadkoppeling)
 Verschraubung mit O-Ring
 Raccord union avec joint torique
 Bocchettone a O-ring
 Enlace de unión con junta torica

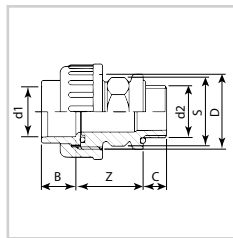

ART.CODE	d1	d2	Z	B	C	D	S	PN	QUANTITY
3.68.018	16	⅜" (M)	36.5	14	10	¾"	25	10	50
3.68.022	20	½" (M)	40	16	10	1"	28	10	50
3.68.027	25	¾" (M)	42	19	12	1¼"	32	10	60
3.68.034	32	1" (M)	43	22	15	1½"	38	10	100
3.68.042	40	1¼" (M)	48	26	15	2"	46	10	50
3.68.052	50	1½" (M)	53.5	31	18	2¼"	55	10	50
3.68.053	50	2" (M)	53.5	31	23.5	2¼"	55	10	25
3.68.065	63	2" (M)	54.5	38	23.5	2¾"	65	10	25

ADAPTOR UNION

Sputigietkoppeling
Verschraubung
Raccord union
Bocchettone
Enlace de unión

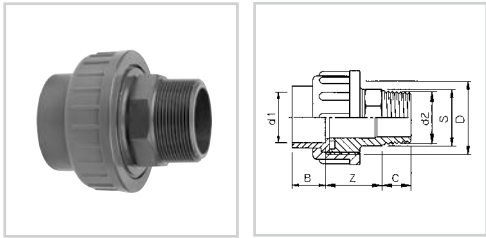

ART.CODE	d1	d2	Z	B	C	D	S	PN	QUANTITY
3.70.010	10	1/4" (M)	27	12	12	5/8"	23	16	100
3.70.012	12	1/4" (M)	27	12	12	5/8"	23	16	100
3.70.016	16	3/8" (M)	31	14	12	3/4"	24	16	100
3.70.020	20	1/2" (M)	32	16	17	1"	28	16	100
3.70.025	25	3/4" (M)	26	19	17	1 1/4"	32	16	60
3.70.032	32	1" (M)	35	22	22	1 1/2"	38	16	100
3.70.040	40	1 1/4" (M)	38	26	24	2"	46	16	80
3.70.050	50	1 1/2" (M)	41	31	24	2 1/4"	55	16	60
3.70.063	63	2" (M)	44	38	28	2 3/4"	65	16	45
3.70.075	75	2 1/2" (M)	56	44	34	ZGTD	94	10	25
3.70.090	90	3" (M)	68	51	37	ZGTD	114	10	15
3.70.110	110	4" (M)	77	60	43	ZGTD	138	10	8

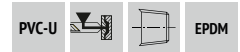

PVC-PE ADAPTOR UNION

PVC-PE overgangskoppeling
PVC-PE Übergangverschraubung
Raccord union d'adaption PVC-PE
Bocchettone PVC-PE
Enlace de unión PVC-PE

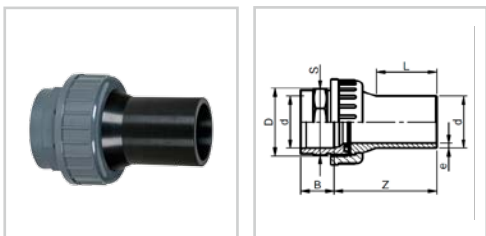

ART.CODE	d	D	B	Z	S	L	e	SDR	P (BAR)*	QUANTITY
3.63.063	63	2 3/4"	38	116	80	70	5.8	11	12.5	3
3.63.064	63	2 3/4"	38	116	80	70	3.8	17	7.5	3
3.63.075	75	ZGTD	44	140	94	81	6.8	11	7.5	3
3.63.076	75	ZGTD	44	140	94	81	4.5	17	7.5	3
3.63.090	90	ZGTD	51	159	114	90	8.2	11	7.5	2
3.63.091	90	ZGTD	51	159	114	90	5.4	17	7.5	2



*Remarks

- Maximum working pressure (P) for water at 20°C and constant load.
- For use at higher temperatures or varying loads, additional reduction factors must be taken into account.

*Opmerkingen

- Maximale werkdruk (P) voor water van 20°C en bij constante belasting.
- Voor gebruik bij hogere temperaturen of wisselende belastingen moet rekening gehouden worden met extra reductie factoren.

*Bemerkungen

- Maximaler Betriebsdruck (P) für Wasser bei 20°C und bei konstanter Belastung.
- Für Einsatz bei höheren Temperaturen oder wechselnden Belastung müssen zusätzliche Reduktionsfaktoren berücksichtigt werden.

*Remarques

- Pression de service maximale (P) pour l'eau à 20°C et à charge constante.
- Pour utilisation à des températures élevées ou des charges variables, des facteurs de réduction additional doit être pris en compte.

PVC-U METRIC

COLLAR (PARTS)

Inlegstuk
Bundbuchse
Collet
Collare
Portabrida

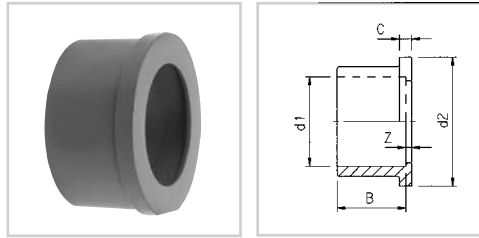

ART.CODE	d1	d2	Z	B	C	QUANTITY
8.25.010	10	5/8"	3	12	4	50
8.25.012	12	5/8"	3	12	4	50
8.25.016	16	3/4"	4	14	5	50
8.25.020	20	1"	4	16	5	50
8.25.025	25	1 1/4"	4	19	6	50
8.25.032	32	1 1/2"	4	22	6	50
8.25.040	40	2"	4	26	7	25
8.25.050	50	2 1/4"	4	31	7	25
8.25.063	63	2 3/4"	4	38	8	25
8.25.075	75	ZGTD	5	44	9	10
8.25.090	90	ZGTD	7	51	10	5
8.25.110	110	ZGTD	7	61	12	5

ADAPTOR NIPPLE (PARTS)

Draadeind
Gewindestück
Collet d'union fileté
Adattore a filetto
Nipple adaptor

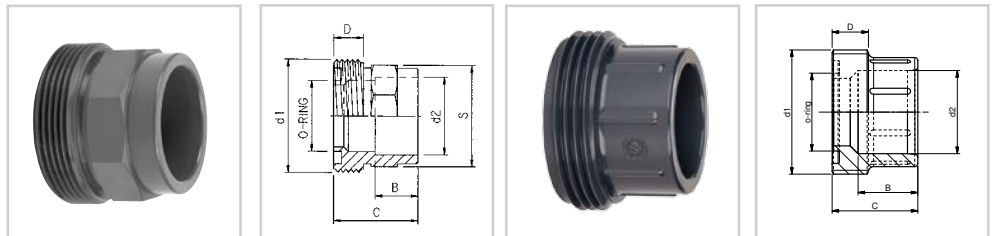

TYPE A

TYPE B



ART.CODE	d1	d2	B	C	D	S	O-RING	TYPE	QUANTITY
8.22.010	5/8" (M)	10	12	31	10	23	12.37x2.62	A	50
8.22.012	5/8" (M)	12	12	31	10	23	12.37x2.62	A	50
8.22.016	3/4" (M)	16	14	33	11	25	15.55x2.62	A	50
8.22.019	1" (M)	20	16	37	12	30	20.22x3.53	B	50
8.22.020	1" (M)	20	16	26	12	-	20.22x3.53	A	50
8.22.024	1 1/4" (M)	25	19	29	12	-	28.17x3.53	B	50
8.22.025	1 1/4" (M)	25	19	38	12	36	28.17x3.53	A	50
8.22.031	1 1/2" (M)	32	22	33	14	-	32.92x3.53	B	50
8.22.032	1 1/2" (M)	32	22	42	14	44	32.92x3.53	A	50
8.22.039	2" (M)	40	26	39	16	-	40.64x5.33	B	50
8.22.040	2" (M)	40	26	45	16	54	40.64x5.33	A	25
8.22.049	2 1/4" (M)	50	31	46	18	-	46.99x5.33	B	25
8.22.050	2 1/4" (M)	50	31	50	18	64	46.99x5.33	A	25
8.22.062	2 3/4" (M)	63	38	56	20	-	59.69x5.33	B	25
8.22.063	2 3/4" (M)	63	38	54	20	80	59.69x5.33	A	25
8.22.075	ZGTD	75	44	66	30	94	78.74x5.33	A	10
8.22.090	ZGTD	90	51	77	35	114	97.79x5.33	A	5
8.22.110	ZGTD	110	61	89	40	138	117.5x5.33	A	5

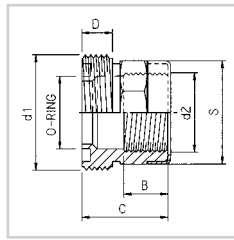
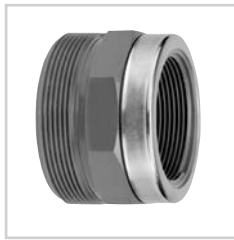
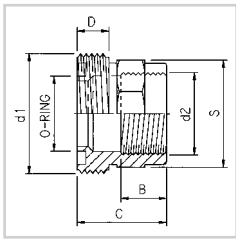
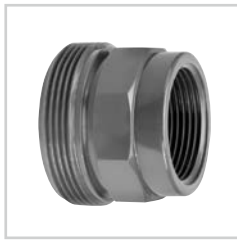

TYPE A

TYPE B

ART.CODE	d1	d2	B	C	D	S	O-RING	TYPE	QUANTITY
8.23.012	⅝" (M)	¼" (F)	12	31	10	23	12.37x2.62	A	50
8.23.016	¾" (M)	⅜" (F)	12	33	11	25	15.55x2.62	A	50
8.23.017	¾" (M)	⅜" (F)	12	33	11	25	15.55x2.62	B	50
8.23.020	1" (M)	½" (F)	16	37	12	30	20.22x3.53	A	50
8.23.021	1" (M)	½" (F)	16	37	12	30	20.22x3.53	B	50
8.23.025	1¼" (M)	¾" (F)	17	38	12	36	28.17x3.53	A	50
8.23.026	1¼" (M)	¾" (F)	17	38	12	36	28.17x3.53	B	50
8.23.032	1½" (M)	1" (F)	21	42	14	44	32.92x3.53	A	50
8.23.033	1½" (M)	1" (F)	21	42	14	44	32.92x3.53	B	50
8.23.040	2" (M)	1¼" (F)	23	45	16	54	40.64x5.33	A	25
8.23.041	2" (M)	1¼" (F)	23	45	16	54	40.64x5.33	B	25
8.23.050	2¼" (M)	1½" (F)	23	50	18	64	46.99x5.33	A	25
8.23.051	2¼" (M)	1½" (F)	23	50	18	64	46.99x5.33	B	25
8.23.063	2¾" (M)	2" (F)	27	54	20	80	59.69x5.33	A	25
8.23.064	2¾" (M)	2" (F)	27	54	20	80	59.69x5.33	B	25
8.23.075	ZGTD	2½" (F)	31	66	30	94	78.74x5.33	B	10
8.23.090	ZGTD	3" (F)	34	77	35	114	97.79x5.33	B	5
8.23.110	ZGTD	4" (F)	41	88	40	138	117.5x5.33	B	5

ADAPTOR NIPPLE (PARTS)

Draadeind
Gewindestück
Collet d'union fileté
Adattore a filetto
Nipple adaptor



TYPE A



TYPE B

PVC-U METRIC

ADAPTOR NIPPLE (PARTS)

Draadeind
Gewindestück
Collet d'union fileté
Adattore a filetto
Nipple adaptor

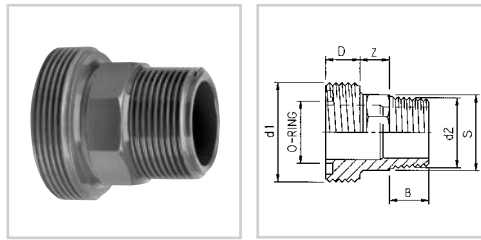

ART.CODE	d1	d2	Z	B	D	S	O-RING	QUANTITY
8.24.012	3/8" (M)	1/4" (M)	14	12	10	23	12.37x2.62	50
8.24.016	3/4" (M)	3/8" (M)	15	12	11	25	15.55x2.62	50
8.24.020	1" (M)	1/2" (M)	17	16	12	28	20.22x3.53	50
8.24.025	1 1/4" (M)	3/4" (M)	18	17	12	32	28.17x3.53	50
8.24.032	1 1/2" (M)	1" (M)	18	21	14	38	32.92x3.53	50
8.24.040	2" (M)	1 1/4" (M)	19	24	16	46	40.64x5.33	25
8.24.050	2 1/4" (M)	1 1/2" (M)	19	24	18	55	46.99x5.33	25
8.24.063	2 3/4" (M)	2" (M)	20	28	20	65	59.69x5.33	25
8.24.075	ZGTD	2 1/2" (M)	21	34	30	94	78.74x5.33	10
8.24.090	ZGTD	3" (M)	25	37	35	114	97.79x5.33	5
8.24.110	ZGTD	4" (M)	28	43	40	138	117.5x5.33	5



UNION NUT (PARTS)

Wartelmoer
Überwurfmutter
Écrou de raccord
Ghiera
Tuerca de enlace

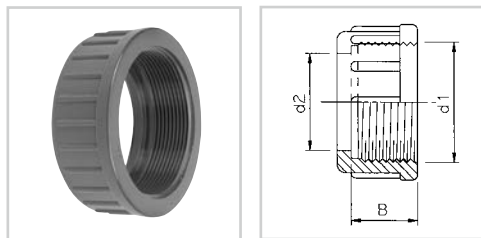

ART.CODE	Dia	d1	d2	B	QUANTITY
8.20.010	10/12	3/8" (F)	18	14	50
8.20.016	16	3/4" (F)	22	16	50
8.20.020	20	1" (F)	27	16	50
8.20.025	25	1 1/4" (F)	36	19	50
8.20.032	32	1 1/2" (F)	41	19	50
8.20.040	40	2" (F)	53	22	25
8.20.050	50	2 1/4" (F)	60	24	25
8.20.063	63	2 3/4" (F)	75	29	25
8.20.075	75	ZGTD" (F)	90	39	10
8.20.090	90	ZGTD (F)	108	44	5
8.20.110	110	ZGTD" (F)	130	49	5



O-RING FOR UNION (PARTS)

O-ring voor spuitgietskoppeling
 O-ring für Verschraubung
 Joint torique pour raccord union
 O-ring per bocchettone
 Junta torica para enlace de unión

EPDM Viton[®]

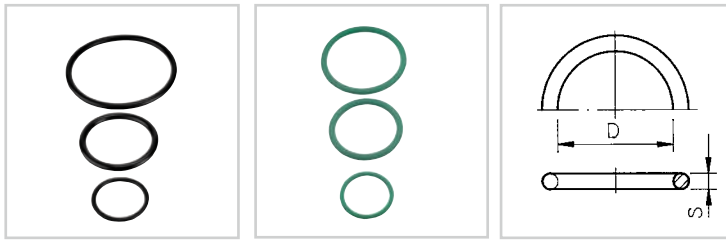

ART.CODE	Dia	D	S	QUANTITY
8.06.016	16	15.55	2.62	100
8.06.020	20	20.22	3.53	250
8.06.025	25	28.17	3.53	500
8.06.032	32	32.92	3.53	100
8.06.040	40	40.64	5.33	100
8.06.050	50	46.99	5.33	100
8.06.063	63	59.69	5.33	100
8.06.075	75	78.74	5.33	50
8.06.090	90	97.79	5.33	50
8.06.110	110	117.50	5.33	50

VITON (F.P.M Colour = green)

ART.CODE	Dia	D	S	QUANTITY
8.36.016	16	15.55	2.62	10
8.36.020	20	20.22	3.53	10
8.36.025	25	28.17	3.53	10
8.36.032	32	32.92	3.53	10
8.36.040	40	40.64	5.33	10
8.36.050	50	46.99	5.33	10
8.36.063	63	59.69	5.33	10
8.36.075	75	78.74	5.33	1
8.36.090	90	97.79	5.33	1

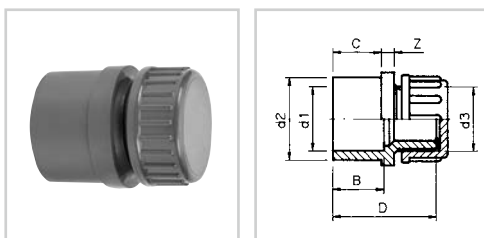

END PART

Eindset
 Endverschluss
 Bouchon terminal
 Tappo final
 Tapón terminal

ART.CODE	d1	d2	d3	Z	B	C	D	PN	QUANTITY
3.77.016	16	-	½"	8	14	-	38	10	250
3.77.020	20	-	½"	8	16	-	40	10	250
3.77.025	25	32	¾"	3	19	22	42	10	500
3.77.032	32	40	1"	2	22	24	44	10	250
3.77.035	32	40	1¼"	2	22	24	44	10	200
3.77.040	40	50	1¼"	10	26	27	60	10	125



PVC-U METRIC

3/3 UNION

3/3 Koppeling
 3/3 Verschraubung
 Raccord union à 3 pieces
 Bocchettone à 3
 Racor union 3 piezas

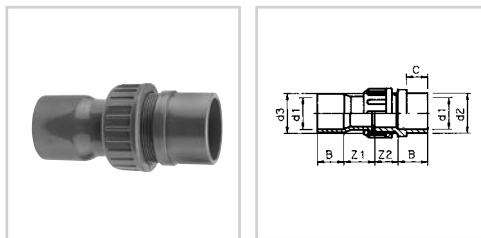

ART.CODE	d1	d2	d3	Z1	Z2	B	C	PN	QUANTITY
5.10.025	25	32	1"	28	23	28	22	10	250
5.10.032	32	40	1¼"	29	21	29	23	10	200
5.10.040	40	50	1½"	36	34	32	28	10	100
5.10.050	50	-	2"	42	39	39	33	10	60
5.10.063	63	75	2½"	44	35	46	42	10	30
5.10.075	75	90	3"	54	38	56	45	6	24

2/3 UNION

2/3 Koppeling
 2/3 Verschraubung
 Raccord union à 2 pieces
 Bocchettone à 2
 Racor union 2 piezas

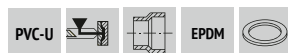
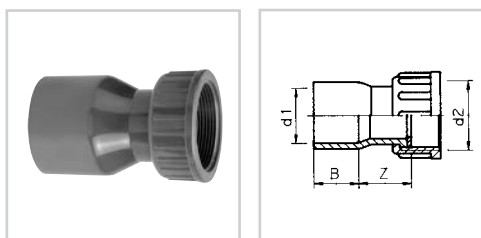

ART.CODE	d1	d2	Z	B	PN	QUANTITY
5.15.010	25	1" (F)	30	27	16	250
5.15.015	32	1" (F)	36	27	10	200
5.15.020	32	1¼" (F)	29	27	16	250
5.15.025	40	1¼" (F)	37	30	10	100
5.15.030	40	1½" (F)	35	35	16	200
5.15.035	50	1½" (F)	45	32	10	100
5.15.040	50	2" (F)	38	42	16	100
5.15.043	63	2" (F)	57	46	10	25
5.15.045	63	2½" (F)	48	42	10	50
5.15.048	75	2½" (F)	52	40	6	25
5.15.050	75	3" (F)	50	55	6	25
5.15.055	90	3" (F)	48	52	6	25

PVC-U METRIC

2/3 UNION

2/3 Koppeling
2/3 Verschraubung
Raccord union à 2 pieces
Bocchettone à 2
Racor union 2 piezas

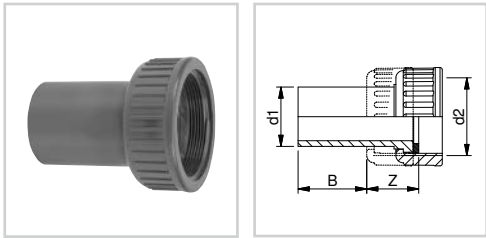

ART.CODE	d1	d2	Z	B	PN	QUANTITY
5.14.020	32	1¼" (F)	25	40	16	100
5.14.030	40	1½" (F)	30	47	16	100
5.14.040	50	2" (F)	32	56	16	50
5.14.045	63	2½" (F)	36	63	10	50
5.14.050	75	3" (F)	42	78	6	25

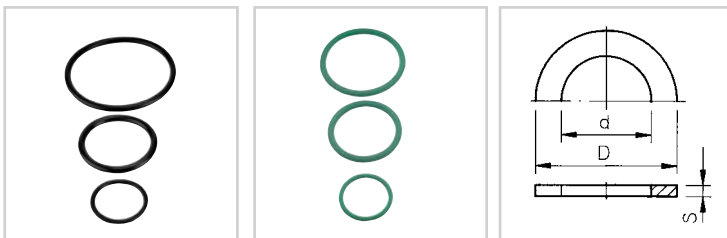
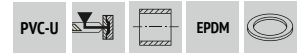

RUBBER WASHER FOR COUPLING (PARTS)

Rubber afdichting voor koppeling
Gummiring für Verschraubung
Joint plat pour union
Guarnizione di gomma per bocchettone
Junta caucho para racor unión

ART.CODE	Dia	d	D	S	QUANTITY
8.05.020	1"	18.5	30	2	500
8.05.025	1¼"	29	39	3	500
8.05.030	1½"	34	45	3	300
8.05.035	2"	44	57	3	150
8.05.040	2½"	57	73	4	100
8.05.045	3"	67	85	4	50

EPDM Viton®

VITON (F.P.M Colour = green)

ART.CODE	Dia	d	D	S	QUANTITY
8.35.020	1"	18.5	30	2	10
8.35.025	1¼"	29	39	3	10
8.35.030	1½"	34	45	3	10
8.35.035	2"	44	57	3	10
8.35.040	2½"	57	73	4	10
8.35.045	3"	67	85	4	10

PVC-U METRIC

TABLE DUCT WITH CLAMPING NUT

Doorvoer met klemring
Durchführung mit Klemmutter
Traversée de paroi avec écrou de calage
Passagio per serbatoio con dado
Pasamuro con anillo de presión

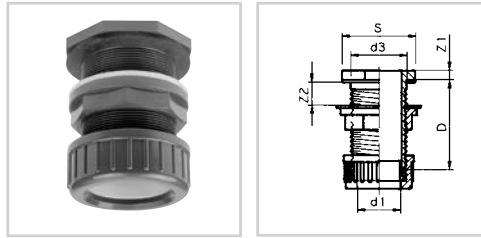
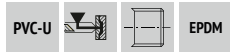

ART.CODE	d1	d3	Z1	Z2	D	S	QUANTITY
5.16.022	20	¾" (M)	8	0-25	56	32	100
5.16.027	25	1" (M)	10	0-25	60	40	100
5.16.032	32	1¼" (M)	7	0-25	66	55	100
5.16.040	40	1¾" (M)	7	0-25	78	74	80
5.16.054	50	2" (M)	9	0-30	84	78	45
5.16.064	63	2½" (M)	9	0-30	90	100	30

TANK CONNECTOR

Tankdoorvoer
Behälteranschluss
Traversée de paroi
Passagio
Pasamuro



TYPE A

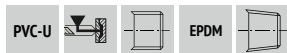

TYPE B

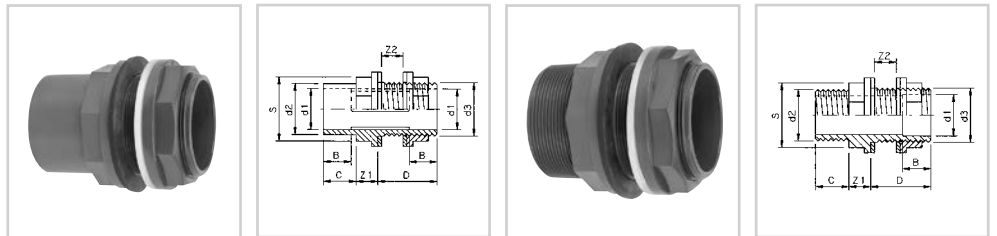

TYPE A

TYPE B

ART.CODE	d1	d2	d3	Z1	Z2	B	C	D	S	TYPE	QUANTITY
5.16.020	20	25	¾" (M)	13	0-23	16	19	42	32	A	50
5.16.021	20	¾" (M)	¾" (M)	13	0-23	16	17	42	32	B	50
5.16.025	25	32	1" (M)	15	0-23	19	22	45	40	A	50
5.16.026	25	1" (M)	1" (M)	15	0-23	19	21	45	40	B	50
5.16.034	32	40	1¼" (M)	17	0-26	22	26	49	50	A	50
5.16.035	32	1¼" (M)	1¼" (M)	17	0-26	22	23	49	50	B	50
5.16.041	40	50	1¾" (M)	19	0-21	26	31	48	60	A	50
5.16.042	40	1½" (M)	1¾" (M)	19	0-21	26	23	48	60	B	50
5.16.048	50	63	2" (M)	21	0-21	31	38	52	69	A	45
5.16.049	50	2" (M)	2" (M)	21	0-21	31	27	52	69	B	45
5.16.050	50	63	2¼" (M)	21	0-21	31	38	52	76	A	45
5.16.051	50	2" (M)	2¼" (M)	21	0-21	31	27	52	76	B	45
5.16.065	63	75	2½" (M)	23	0-23	38	44	53	85	A	24
5.16.066	63	2½" (M)	2½" (M)	23	0-23	38	31	53	85	B	24
5.16.075	75	90	3" (M)	26	0-20	44	51	56	100	A	21
5.16.076	75	3" (M)	3" (M)	26	0-20	44	34	56	100	B	21
5.16.090	90	110	M113 (M)	32	0-20	51	61	62	126	A	10
5.16.091	90	4" (M)	M113 (M)	32	0-20	51	40	62	126	B	10
5.16.110	110	125	M133 (M)	36	0-22	61	69	66	147	A	10

PVC-U METRIC

TANK CONNECTOR

Tankdoorvoer
Behälteranschluss
Traversée de pario
Passagio
Pasamuro

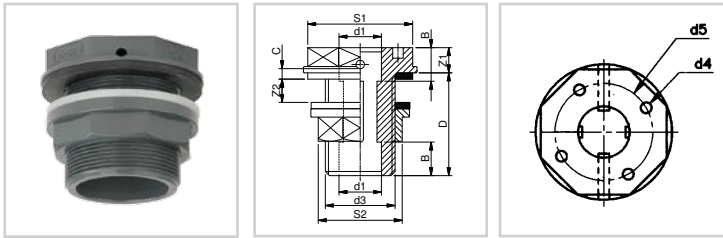

ART.CODE	d1	d3	d4	d5	Z1	Z2	B	C	D	S1	S2	QUANTITY
5.17.016	16	¾" (M)	5	29	11	0-28	14	5	47	40	32	50
5.17.020	20	1" (M)	5	36	12	0-28	16	5	49	50	40	50
5.17.025	25	1¼" (M)	5	42	13	0-28	19	5	52	50	50	75
5.17.032	32	1½" (M)	5	49	13	0-28	22	5	54	64	56	50
5.17.040	40	2" (M)	5	59	13	0-29	26	6	59	78	69	45
5.17.050	50	2¼" (M)	5	70	15	0-30	31	6	61	85	76	45
5.17.063	63	2¾" (M)	5	84	15	0-35	38	6	69	100	95	20

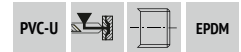

TANK CONNECTOR WITH UNION PART

Tankdoorvoer met koppeling
Behälteranschluss mit
Verschraubung
Traversée de pario avec union
Passagio con becchettone
Pasamuro con enlace de unión

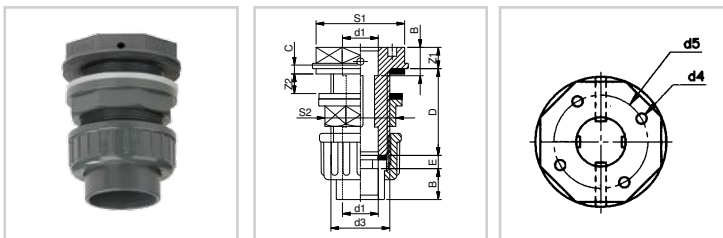

ART.CODE	d1	d3	d4	d5	Z1	Z2	B	C	D	E	S1	S2	QUANTITY
5.18.016	16	¾" (M)	5	29	11	0-19	14	5	47	6	40	32	50
5.18.020	20	1" (M)	5	36	12	0-17	16	5	49	6	50	40	50
5.18.025	25	1¼" (M)	5	42	13	0-18	19	5	52	6	50	50	75
5.18.032	32	1½" (M)	5	49	13	0-19	22	5	54	6	64	56	50
5.18.040	40	2" (M)	5	59	13	0-16	26	6	59	6.5	78	69	40
5.18.050	50	2¼" (M)	5	70	15	0-16	31	6	61	6.5	85	76	40
5.18.063	63	2¾" (M)	5	84	15	0-19	38	6	69	6.5	100	95	25



PVC-U METRIC

PVC NUT (PARTS)

PVC moer
PVC Mutter
PVC écrou
PVC madrevite
Tuerca PVC Hexonal

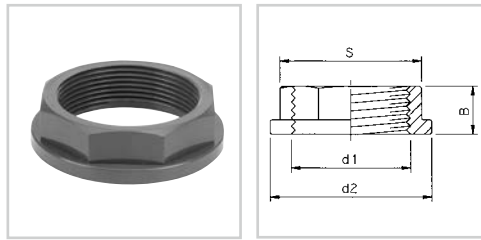

ART.CODE	d1	d2	B	S	QUANTITY
8.11.020	¾" (F)	39	13	32	50
8.11.025	1" (F)	47	15	40	50
8.11.032	1¼" (F)	58	17	50	50
8.11.035	1½" (F)	65	18	56	50
8.11.040	1¾" (F)	72	19	64	50
8.11.045	2" (F)	79	21	69	50
8.11.050	2¼" (F)	86	22	76	50
8.11.063	2½" (F)	95	23	85	25
8.11.065	2¾" (F)	106	25	95	25
8.11.075	3" (F)	112	26	100	20
8.11.090	M113 (F)	139	32	127	10
8.11.110	M133 (F)	170	36	154	10
8.11.140	4" (F)	139	32	126	10
8.11.150	5" (F)	170	36	154	10

PP SLIPRING (PARTS)

PP Glijring
PP Gleitring
Joint à glissement PP
Amello suvocare PP
Junta plana PP

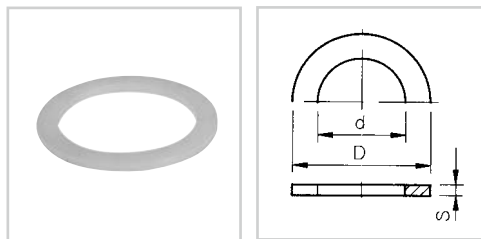

ART.CODE	Dia	d	D	S	QUANTITY
8.08.020	¾"	27	39	3	50
8.08.025	1"	34	47	3	50
8.08.032	1¼"	43	58	3	50
8.08.035	1½"	49	65	4	50
8.08.040	1¾"	55	72	4	50
8.08.045	2"	61	79	4	50
8.08.050	2¼"	67	86	4	50
8.08.063	2½"	77	95	4	25
8.08.065	2¾"	83	106	4	20
8.08.075	3"	90	112	5	20
8.08.090	M113	115	139	5	10
8.08.110	M133	135	160	5	10
8.08.125	M140	140	160	5	10

PVC-U METRIC

RUBBER WASHER (PARTS)

Rubber afdichting
Gummiring
Joint plat
Guarnizione di gomma
Junta caucho

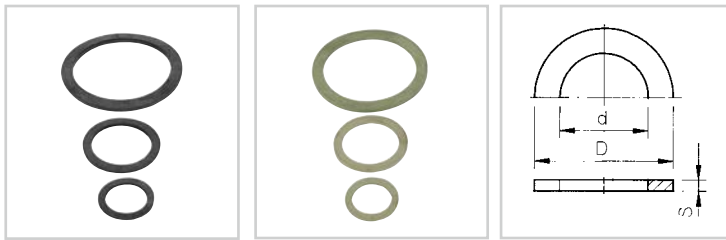

ART.CODE	Dia	d	D	S	QUANTITY
8.05.100	¾"	27	41	3	500
8.05.105	1"	33	50	3	300
8.05.110	1¼"	42	60	3	150
8.05.115	1¾"	53	75	4	100
8.05.120	2"	59	83	4	100
8.05.125	2¼"	65	90	4	50
8.05.130	2½"	75	100	4	50
8.05.047	2¾"	83	106	4	50
8.05.050	3"	88	110	5	10
8.05.135	M113	111	145	5	10
8.05.140	M133	133	170	5	10

VITON (F.P.M Colour = green)

ART.CODE	Dia	D	D	S	QUANTITY
8.35.025	¾"	29	39	3	10
8.35.030	1"	34	45	3	10
8.35.035	1¼"	44	57	3	10
8.35.040	1¾"-2"	57	73	4	10
8.35.045	2¼"	67	85	4	10
8.35.046	2½"	77	95	4	10
8.35.050	3"	88	110	5	10
8.35.055	M113	115	135	5	10

EPDM Viton

PVC-U METRIC

TUBE CLIP

Buisklem
Rohrklemme
Clip de fixation
Supporto per tubi
Abrazadera para tubos

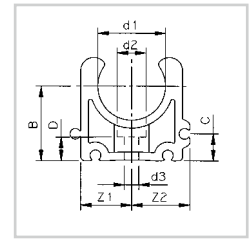
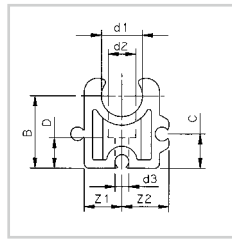

TYPE A

TYPE B

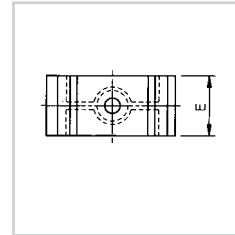
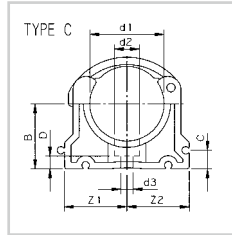

TYPE C

ART.CODE	d1	d2	d3	Z1	Z2	B	C	D	E	TYPE	QUANTITY
5.25.010	10	8.3	4.5	11	13.5	20	10	6	12	A	500 (50x10)
5.25.012	12	8.3	4.5	11	13.5	21	10	6	12	A	500 (50x10)
5.25.016	16	10.5	5.5	14	16.5	23	10	6	16	B	400 (40x10)
5.25.020	20	10.5	5.5	16.5	19	25	10	6	16	B	400 (40x10)
5.25.025	25	10.5	5.5	19	21.5	27.5	10	6	16	B	800 (80x10)
5.25.032	32	10.5	5.5	24	26.5	31	10	6	16	B	600 (60x10)
5.25.033	32	14	6.5	28.5	28.5	31	10	6.5	22	C	400 (40x10)
5.25.040	40	14	6.5	33.5	33.5	35	10	6.5	22	C	250 (25x10)
5.25.050	50	14	6.5	37	37	40	10	6.5	22	C	250 (25x10)
5.25.063	63	17	8.5	44.5	44.5	51.5	10	10	25	C	150 (15x10)
5.25.075	75	17	8.5	52	52	57.5	10	10	25	C	80 (8x10)
5.25.090	90	17	8.5	64.5	64.5	65	10	10	28	C	60 (6x10)
5.25.110	110	17	8.5	78	78	75	10	10	28	C	50 (5x10)
5.25.125	125	17	8.5	88	88	90	10	10	31.5	C	40 (4x10)
5.25.140	140	17	8.5	97	97	110	10	10	31.5	C	20 (2x10)
5.25.160	160	17	8.5	109	109	107.5	10	10	31.5	C	20 (2x10)

Advised installation distances for VDL tube clips and tube clamps can be found on www.vandelande.com.
 Advies montage afstanden voor VDL buisklemmen en buisbeugels zijn te vinden op www.vandelande.com.
 Empfohlene Montageabstände für VDL Rohrklemmen und Rohrbügel finden Sie auf www.vandelande.com.
 Vous trouvez l'avis montage-distances pour les VDL clips de fixation à www.vandelande.com.
 Lei trovare consiglio per distanza di montaggio per VDL supporto per tubi a www.vandelande.com.
 Usted encuentre consulta distancia de montaje para VDL abrazadera para tubos en www.vandelande.com.

FILLING BLOCK

Vulblokje
Distanzhalter
Bloc à reveler
Distanziatore
Soporte de relleno

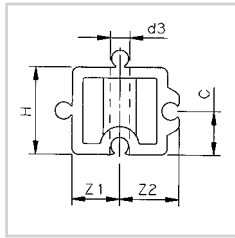

TYPE D

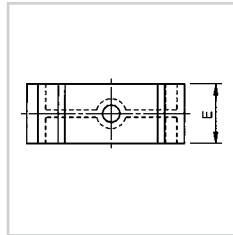
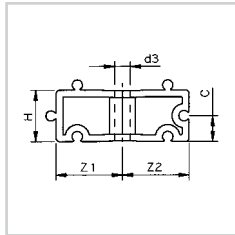

TYPE E



ART.CODE	SIZE	d3	Z1	Z2	H	C	E	TYPE	QUANTITY
5.24.011	10	4.5	11	13.5	20	10	12	D	500 (50x10)
5.24.011	12	4.5	11	13.5	20	10	12	D	500 (50x10)
5.24.016	16	5.5	14	16.5	20	10	16	E	400 (40x10)
5.24.020	20	5.5	16.5	19	20	10	16	E	400 (40x10)
5.24.025	25	5.5	19	21.5	20	10	16	E	800 (80x10)
5.24.032	32	5.5	24	26.5	20	10	16	E	600 (60x10)
5.24.033	32	6.5	28.5	28.5	20	10	22	E	400 (40x10)
5.24.040	40	6.5	33.5	33.5	20	10	22	E	250 (25x10)
5.24.050	50	6.5	37	37	20	10	22	E	250 (25x10)
5.24.063	63	8.5	44.5	44.5	20	10	25	E	150 (15x10)
5.24.075	75	8.5	52	52	20	10	25	E	80 (8x10)
5.24.090	90	8.5	64.5	64.5	20	10	28	E	100 (10x10)
5.24.110	110	8.5	78	78	20	10	28	E	80 (8x10)
5.24.125	125	8.5	88	88	20	10	31.5	E	150 (15x10)
5.24.140	140	8.5	97	97	20	10	31.5	E	140 (14x10)
5.24.160	160	8.5	109	109	20	10	31.5	E	120 (12x10)

TUBE CLAMP

Buisbeugel
Rohrklemme
Clip de fixation
Supporto per tubi
Abrazadera para tubos

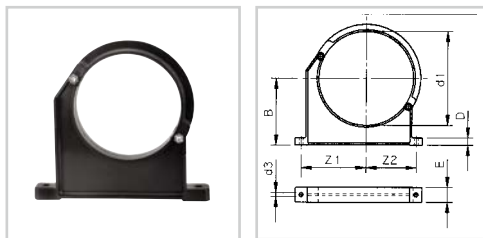

TYPE F



ART.CODE	d1	d3	Z1	Z2	B	D	E	TYPE	QUANTITY
5.26.090	90	9	89	71	105	15	33	F	60
5.26.110	110	9	94	79.5	115	15	33	F	40
5.26.125	125	11	115.5	91	130	20	35	F	40
5.26.140	140	11	120.5	97.5	130	20	35	F	40
5.26.160	160	11	130.5	106.5	147.5	20	35	F	20
5.26.180	180	11	142.5	115	162.5	20	35	F	10
5.26.200	200	13	151.5	119.5	175	25	40	F	10
5.26.225	225	13	164.5	131.5	175	25	40	F	10
5.26.250	250	13	182.5	142.5	200	25	40	F	10
5.26.280	280	13	197.5	155.5	200	25	40	F	10
5.26.315	315	13	218.5	171.5	225	25	40	F	10
5.26.355	355	17	276	210	257	30	50	F	10
5.26.400	400	17	301	230	288	30	50	F	10

Advised installation distances for VDL tube clips and tube clamps can be found on www.vandelande.com.
 Advies montage afstanden voor VDL buisklemmen en buisbeugels zijn te vinden op www.vandelande.com.
 Empfohlene Montageabstände für VDL Rohrklemmen und Rohrbügel finden Sie auf www.vandelande.com.
 Vous trouvez l'avis montage-distances pour les VDL clips de fixation à www.vandelande.com.
 Lei trovare consiglio per distanza di montaggio per VDL supporto per tubi a www.vandelande.com.
 Usted encuentre consulta distancia de montaje para VDL abrazadera para tubos en www.vandelande.com.

BALL VALVE TYPE: EIL

Kogelkraan type: Eil
Kugel Hahn Type: Eil
Vanne à boisseau type: Eil
Valvola a sfera tipo: Eil
Válvula de bola tipo: Eil

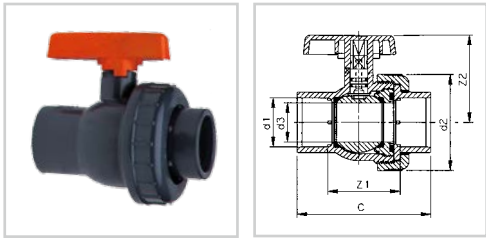

ART.CODE	d1	d2	d3	Z1	Z2	C	DN	PN	QUANTITY	REPLACEMENT KIT
6.05.016	16	59	15	43.5	50	77	10	16	50	6.40.020
6.05.020	20	59	15	43.5	50	77	15	16	50	6.40.020
6.05.025	25	64	20	47.5	55	87	20	16	50	6.40.025
6.05.032	32	73	25	55.0	65	100	25	16	50	6.40.032
6.05.040	40	86	32	61.0	75	114	32	16	25	6.40.040
6.05.050	50	102	40	74.5	90	138	40	16	20	6.40.050
6.05.063	63	124	50	93.0	103	167	50	16	10	6.40.063

Flush out secured.
Uitstroom beveiligd.
Die kugel ist gesichert gegen herauspülen.

Logement du boisseau sécurisé.
Componenti interni della valvola bloccati.
Bola y juntas aseguradas contra arresre.



BALL VALVE TYPE: EIL

Kogelkraan type: Eil
Kugel Hahn Type: Eil
Vanne à boisseau type: Eil
Valvola a sfera tipo: Eil
Válvula de bola tipo: Eil

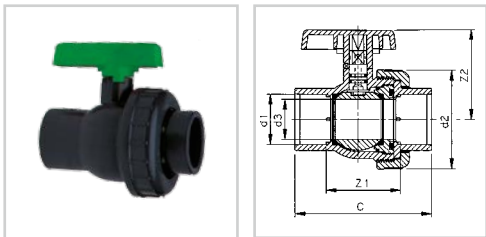

ART.CODE	d1	d2	d3	Z1	Z2	C	DN	PN	QUANTITY	REPLACEMENT KIT
6.06.016	16	59	15	43.5	50	77	10	16	50	6.42.020
6.06.020	20	59	15	43.5	50	77	15	16	50	6.42.020
6.06.025	25	64	20	47.5	55	87	20	16	50	6.42.025
6.06.032	32	73	25	55.0	65	100	25	16	50	6.42.032
6.06.040	40	86	32	61.0	75	114	32	16	25	6.42.040
6.06.050	50	102	40	74.5	90	138	40	16	20	6.42.050
6.06.063	63	124	50	93.0	103	167	50	16	10	6.42.063

Flush out secured.
Uitstroom beveiligd.
Die kugel ist gesichert gegen herauspülen.

Logement du boisseau sécurisé.
Componenti interni della valvola bloccati.
Bola y juntas aseguradas contra arresre.



PVC-U METRIC

BALL VALVE TYPE: EID

Kogelkraan type: Eid
Kugel Hahn Type: Eid
Vanne à boisseau type: Eid
Valvola a sfera tipo: Eid
Válvula de bola tipo: Eid

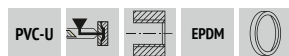
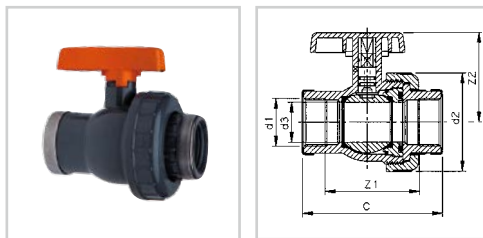

ART.CODE	d1	d2	d3	Z1	Z2	C	DN	PN	QUANTITY	REPLACEMENT KIT
6.10.016	3/8" (F)	59	15	44.5	50	77	10	16	50	6.40.020
6.10.020	1/2" (F)	59	15	44.5	50	77	15	16	50	6.40.020
6.10.025	3/4" (F)	64	20	52.5	55	87	20	16	50	6.40.025
6.10.032	1" (F)	73	25	58.0	65	100	25	16	50	6.40.032
6.10.040	1 1/4" (F)	86	32	58.0	75	114	32	16	25	6.40.040
6.10.050	1 1/2" (F)	102	40	91.5	90	138	40	16	20	6.40.050
6.10.063	2" (F)	124	50	107.0	103	167	50	16	10	6.40.063

Flush out secured.
Uitstroom beveiligd.
Die kugel ist gesichert gegen herauspülen.

Logement du boisseau sécurisé.
Componenti interni della valvola bloccati.
Bola y juntas aseguradas contra arresre.

BALL VALVE TYPE: DIL

Kogelkraan type: Dil
Kugel Hahn Type: Dil
Vanne à boisseau type: Dil
Valvola a sfera tipo: Dil
Válvula de bola tipo: Dil

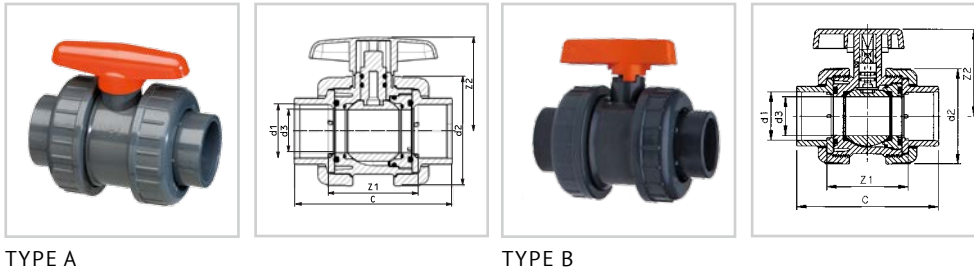

TYPE A

TYPE B

ART.CODE	d1	d2	d3	Z1	Z2	C	DN	PN	TYPE	QUANTITY	REPLACEMENT KIT
6.15.016	16	59	15	54	56	84	10	16	A	50	6.40.021
6.15.020	20	59	15	50	56	84	15	16	A	50	6.40.021
6.15.025	25	64	20	54	57	94	20	16	A	50	6.40.026
6.15.032	32	73	25	64	66	110	25	16	A	50	6.40.033
6.15.040	40	86	32	69	75	122	32	16	A	25	6.40.041
6.15.050	50	102	40	87	90	150	40	16	A	15	6.40.051
6.15.063	63	124	50	102	102	180	50	16	A	10	6.40.064
6.15.075	75	151	63	128	123	217	65	10	B	5	6.40.075
6.15.090	90	178.5	75	152	143	255	80	10	B	3	6.40.090
6.15.110	110	215.5	90	184	161	307	100	10	B	1	6.40.110

Flush out secured.

Uitstroom beveiligd.

Die kugel ist gesichert gegen herauspülen.

Logement du boisseau sécurisé.

Componenti interni della valvola bloccati.

Bola y juntas aseguradas contra arresre.



BALL VALVE TYPE: DIL

Kogelkraan type: Dil
Kugel Hahn Type: Dil
Vanne à boisseau type: Dil
Valvola a sfera tipo: Dil
Válvula de bola tipo: Dil

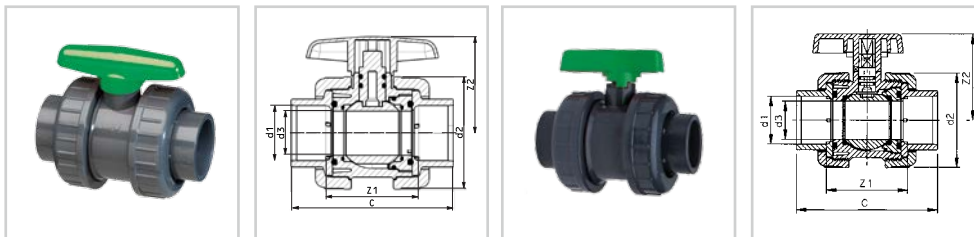

TYPE A

TYPE B

ART.CODE	d1	d2	d3	Z1	Z2	C	DN	PN	Type	QUANTITY	REPLACEMENT KIT
6.16.016	16	59	15	54	56	84	10	16	A	50	6.42.021
6.16.020	20	59	15	50	56	84	15	16	A	50	6.42.021
6.16.025	25	64	20	54	57	94	20	16	A	50	6.42.026
6.16.032	32	73	25	64	66	110	25	16	A	50	6.42.033
6.16.040	40	86	32	69	75	122	32	16	A	25	6.42.041
6.16.050	50	102	40	87	90	150	40	16	A	15	6.42.051
6.16.063	63	124	50	102	102	180	50	16	A	10	6.42.064
6.16.075	75	151	63	128	123	217	65	10	B	5	6.42.075
6.16.090	90	178.5	75	152	143	255	80	10	B	3	6.42.090
6.16.110	110	215.5	90	184	161	307	100	10	B	1	6.42.110

Flush out secured.

Uitstroom beveiligd.

Die kugel ist gesichert gegen herauspülen.

Logement du boisseau sécurisé.

Componenti interni della valvola bloccati.

Bola y juntas aseguradas contra arresre.



PVC-U METRIC

BALL VALVE TYPE: DID

Kogelkraan type: DID
Kugel Hahn Type: DID
Vanne à boisseau type: DID
Valvola a sfera tipo: DID
Válvula de bola tipo: DID

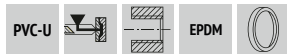

TYPE A

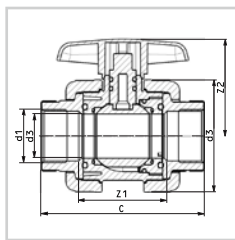

TYPE B

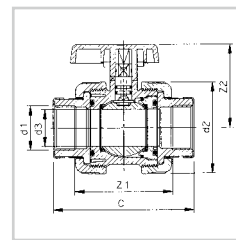

ART.CODE	d1	d2	d3	Z1	Z2	C	DN	PN	TYPE	QUANTITY	REPLACEMENT KIT
6.20.016	3/8" (F)	59	15	52.0	56	84	10	16	A	50	6.40.021
6.20.020	1/2" (F)	59	15	52.0	56	84	15	16	A	50	6.40.021
6.20.025	3/4" (F)	64	20	59.0	57	94	20	16	A	50	6.40.026
6.20.032	1" (F)	73	25	66.0	66	110	25	16	A	50	6.40.033
6.20.040	1 1/4" (F)	86	32	76.0	75	122	32	16	A	25	6.40.041
6.20.050	1 1/2" (F)	102	40	102.0	90	150	40	16	A	15	6.40.051
6.20.063	2" (F)	124	50	107.0	102	180	50	16	A	10	6.40.064
6.20.075	2 1/2" (F)	151	63	144.0	123	217	65	10	B	5	6.40.075
6.20.090	3" (F)	178.5	75	178.0	143	255	80	10	B	3	6.40.090
6.20.110	4" (F)	215.5	90	214.0	161	307	100	10	B	1	6.40.110

Flush out secured.
Uitstroom bevEiligd.
Die kugel ist gesichert gegen herauspülen.

Logement du boisseau sécurisé.
Componenti interni della valvola bloccati.
Bola y juntas aseguradas contra arresre.

BALL VALVE ISO TOP

Kogelkraan ISO Top
Kugel Hahn ISO Top
Vanne à boisseau ISO Top
Valvola a sfera ISO Top
Válvula de bola ISO Top

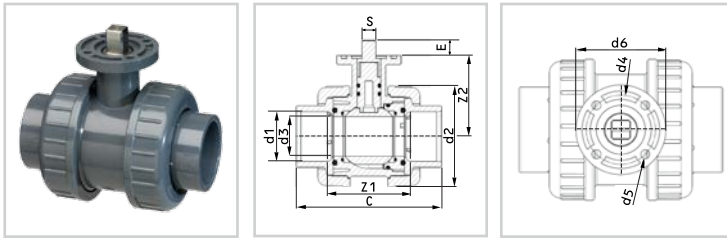

ART.CODE	d1	d2	d3	Z1	Z2	C	DN	PN	QUANTITY
6.14.032	32	73	25	64	60.5	110	25	16	12 (6x2)
6.14.050	50	102	40	87	81.5	150	40	16	6 (6x1)
6.14.063	63	124	50	102	93.5	180	50	16	6 (6x1)

ART.CODE	d4	d5	d6	E	S	ISO 5211	TORQUE
6.14.032	42	5.5	54	11	11	ISO 5211 - F04 - Y - L - 11	4.5 Nm*
6.14.050	50	6.5	65	15	14	ISO 5211 - F05 - Y - L - 14	7.5 Nm*
6.14.063	50	6.5	65	15	14	ISO 5211 - F05 - Y - L - 14	11 Nm*

* Average value at nominal pressure

The torque of the actuator should be about 2x as high as the average torque value from the Ball Valve to take into account the influence of operating conditions. The exact factor depends upon the application.

* Gemiddelde waarden bij nominale druk

Het koppel van de aandrijving moet ca. 2x zo hoog zijn als het gemiddelde draaimoment van de kogelkraan om rekening te houden met de invloed van gebruikscondities. De exacte hoogte van deze factor is afhankelijk van de toepassing.

* Mittelwert bei Nominale Druck

Das Drehmoment des Antriebs muß ungefähr 2x so hoch sein wie das Drehmoment des Kugelhahns wegen Anwendungseinflüsse. Die genaue Faktor ist abhängig von die Anwendung.



BALL VALVE ISO TOP

Kogelkraan ISO Top
Kugel Hahn ISO Top
Vanne à boisseau ISO Top
Valvola a sfera ISO Top
Válvula de bola ISO Top

PVC-U



Viton®

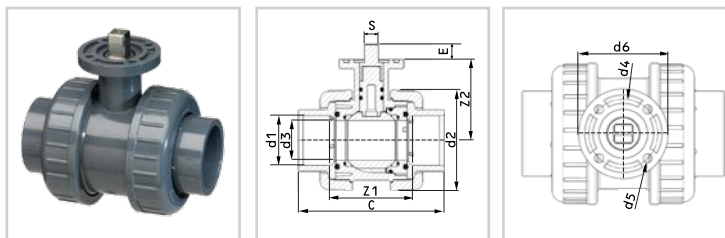

ART.CODE	d1	d2	d3	Z1	Z2	C	DN	PN	QUANTITY
6.17.032	32	73	25	64	60.5	110	25	16	12 (6x2)
6.17.050	50	102	40	87	81.5	150	40	16	6 (6x1)
6.17.063	63	124	50	102	93.5	180	50	16	6 (6x1)

ART.CODE	d4	d5	d6	E	S	ISO 5211	TORQUE
6.17.032	42	5.5	54	11	11	ISO 5211 - F04 - Y - L - 11	4.5 Nm*
6.17.050	50	6.5	65	15	14	ISO 5211 - F05 - Y - L - 14	7.5 Nm*
6.17.063	50	6.5	65	15	14	ISO 5211 - F05 - Y - L - 14	11 Nm*

* Average value at nominal pressure

The torque of the actuator should be about 2x as high as the average torque value from the Ball Valve to take into account the influence of operating conditions. The exact factor depends upon the application.

* Gemiddelde waarden bij nominale druk

Het koppel van de aandrijving moet ca. 2x zo hoog zijn als het gemiddelde draaimoment van de kogelkraan om rekening te houden met de invloed van gebruikscondities. De exacte hoogte van deze factor is afhankelijk van de toepassing.

* Mittelwert bei Nominale Druck

Das Drehmoment des Antriebs muß ungefähr 2x so hoch sein wie das Drehmoment des Kugelhahns wegen Anwendungseinflüsse. Die genaue Faktor ist abhängig von die Anwendung.

PVC-U METRIC

HANDLE FOR BALL VALVE (PARTS)

Handgreep kogelkraan
Handgriff Kugelhahn
Poignée vanne à boisseau
Presa di valvola a sfera
Maneta de válvula de bola

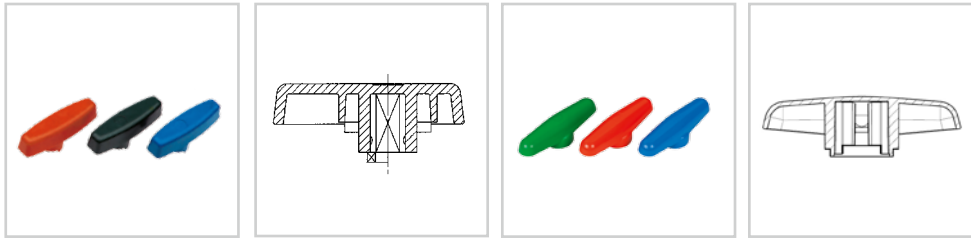

TYPE A

TYPE B

ART.CODE	TYPE	BALL VALVE	QUANTITY
8.58.020	A	6.05.016 - 6.05.020 - 6.10.016 - 6.10.020	25
8.58.021	B	6.15.016 - 6.15.020 - 6.20.016 - 6.20.020	25
8.58.025	A	6.05.025 - 6.10.025	25
8.58.026	B	6.15.025 - 6.20.025	25
8.58.032	A	6.05.032 - 6.10.025	25
8.58.033	B	6.15.032 - 6.20.032	25
8.58.040	A	6.05.040 - 6.10.040	25
8.58.041	B	6.15.040 - 6.20.040	25
8.58.050	A	6.05.050 - 6.10.050	25
8.58.051	B	6.15.050 - 6.20.050	25
8.58.063	A	6.05.063 - 6.10.063	25
8.58.064	B	6.15.063 - 6.20.063	25
8.58.075	A	6.15.075 - 6.20.075	10
8.58.090	A	6.15.090 - 6.20.090	10
8.58.110	A	6.15.110 - 6.20.110	10

ART.CODE	COLOR	ART.CODE	COLOR
BLA858***	■	WIT858***	□
GRO858***	■	ZWA858**	■
GRI858***	■		

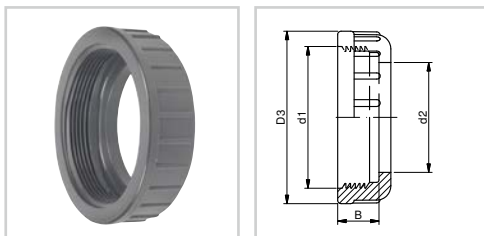

ART.CODE	d1	d2	d3	B	DN	QUANTITY
6.24.020	47	32.0	59	16	10/15	50
6.24.025	51	38.0	64	19	20	50
6.24.032	59	46.5	73	22	25	50
6.24.040	70	55.5	86	26	32	25
6.24.050	84	66.0	102	31	40	20
6.24.063	101	83.0	124	38	50	20
6.24.075	127	98.0	151	36	65	10
6.24.090	152	116.0	158.5	43	80	10
6.24.110	182	139.0	215.5	57	100	10

UNION NUTT BALL VALVE (PARTS)

Wartel kogelkraan
Überwurfmutter Kugelhahn
Écrou vanne à boisseau
Gheira valvola a sfera
Tuerca union válvula



PVC-U METRIC

COLLAR MALE SPIGOT (OPTION)

Inlegstuk uitwendig lijm
Bundbuchse Klebestutzen
Collet à coller male
Collare maschio
Portabrida encolar macho

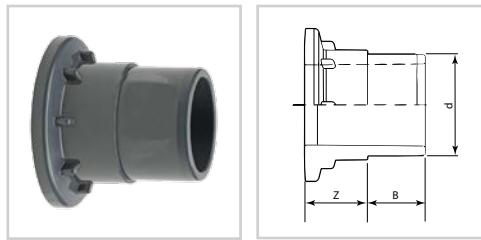

ART.CODE	d	Z	B	DN	QUANTITY
6.25.050	50	33	31	40	1
6.25.063	63	39	38	50	1

PVC-U



COLLAR SOLVENT SOCKET (PARTS)

Inlegstuk inwendig lijm
Bundbuchse Klebemuffe
Collet à coller femelle
Collare a attacchi incollaggio
Portabrida encolar

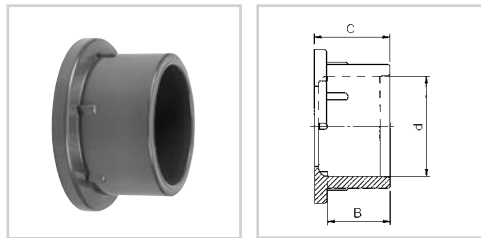

ART.CODE	d	B	C	DN	QUANTITY
6.26.016	16	14	20.5	10	50
6.26.020	20	16	20.5	15	50
6.26.025	25	19	23.5	20	50
6.26.032	32	22	27.5	25	50
6.26.040	40	26	32.0	32	25
6.26.050	50	31	38.0	40	20
6.26.063	63	38	49.0	50	20
6.26.075	75	44	54.5	65	10
6.26.090	90	51	63.0	80	10
6.26.110	110	61	76.5	100	10

PVC-U



COLLAR FEMALE THREADED (PARTS)

Inlegstuk inwendig draad
Bundbuchse Innengewinde
Collet taraudé
Collare attacchi filetati femmina
Portabrida encolar rosca hembra

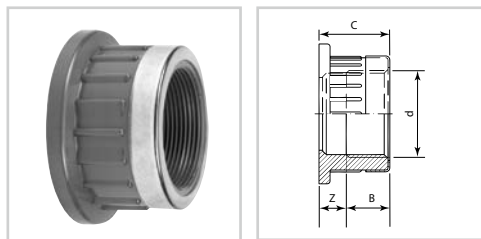

ART.CODE	d	B	C	Z	DN	QUANTITY
6.30.016	3/8" (F)	13	20.5	7.5	10	50
6.30.020	1/2" (F)	17	20.5	3.5	15	50
6.30.025	3/4" (F)	19	23.5	4.5	20	50
6.30.032	1" (F)	21	27.5	6.5	25	50
6.30.040	1 1/4" (F)	21	32.0	11	32	25
6.30.050	1 1/2" (F)	29	38.0	9	40	20
6.30.063	2" (F)	32	49.0	17	50	20
6.30.075	2 1/2" (F)	36	54.5	18.5	65	10
6.30.090	3" (F)	39	63.0	24	80	10
6.30.110	4" (F)	46	76.5	30.5	100	10

PVC-U

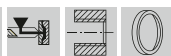

PE CONNECTOR FOR BALL VALVE (OPTION)

PE inlegdeel voor kogelkraan
PE Einlegeteil für Kugelhahn
Pièce folle en PE pour vanne à bille
Collare PE valvola a sfera
Portabrida PE válvula de bola

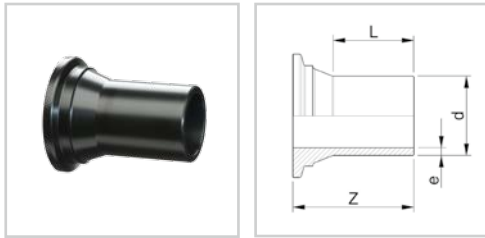

ART.CODE	d	Z	L	e	SDR	(BAR) P*	QUANTITY
6.31.020	20	67	45	2.0	11	12.5	25
6.31.025	25	68	45	2.3	11	12.5	25
6.31.032	32	71	45	3.0	11	12.5	25
6.31.040	40	80	50	3.7	11	12.5	15
6.31.050	50	89	57	4.6	11	12.5	10
6.31.063	63	105	70	5.8	11	12.5	5
6.31.064	63	105	70	3.8	17	7.5	5
6.31.075	75	123	81	6.8	11	7.5	5
6.31.076	75	123	81	4.5	17	7.5	5
6.31.090	90	137	90	8.2	11	7.5	3
6.31.091	90	137	90	5.4	17	7.5	3

*Remarks

- Maximum working pressure (P) for water at 20°C and constant load.
- For use at higher temperatures or varying loads, additional reduction factors must be taken into account.

*Opmerkingen

- Maximale werkdruk (P) voor water van 20°C en bij constante belasting.
- Voor gebruik bij hogere temperaturen of wisselende belastingen moet rekening gehouden worden met extra reductiefactoren.

*Bemerkungen

- Maximaler Betriebsdruck (P) für Wasser bei 20°C und bei konstanter Belastung.
- Für Einsatz bei höheren Temperaturen oder wechselnden Belastung müssen zusätzliche Reduktionsfaktoren berücksichtigt werden.

*Remarques

- Pression de service maximale (P) pour l'eau à 20°C et à charge constante.
- Pour utilisation à des températures élevées ou des charges variables, des facteurs de réduction additional doit être pris en compte.

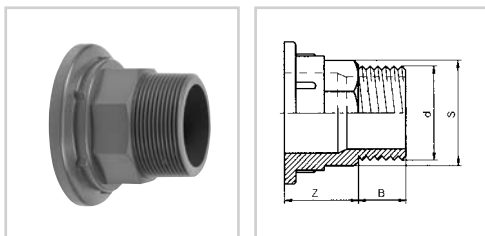

ART.CODE	d	Z	B	S	DN	QUANTITY
6.32.020	½" (M)	21	17	24	15	50
6.32.025	¾" (M)	20	19	29	20	50
6.32.032	1" (M)	25	21	36	25	50
6.32.040	1¼" (M)	31	21	44	32	20
6.32.050	1½" (M)	29	29	52	40	20
6.32.063	2" (M)	36	32	63	50	20

COLLAR MALE THREADED (OPTION)

Inlegstuk uitwendig draad
Bundbuchse Aussengewinde
Collet fileté
Collare attacchi filetati maschio
Portabrida encolar rosca macho



PVC-U METRIC

REPLACEMENT KIT

Vervang set
Ersatzungs kit
Jeu de rechange
Ki di Pezzi di ricambio
Kit Recambio

EPDM

Viton



E.P.D.M. rubber

ART.CODE	BALL VALVE
6.40.020	6.05.016 - 6.10.016 - 6.10.020 - 6.10.020
6.40.021	6.15.016 - 6.15.020 - 6.20.016 - 6.20.020
6.40.025	6.05.025 - 6.10.025
6.40.026	6.15.025 - 6.20.025
6.40.032	6.05.032 - 6.10.025
6.40.033	6.15.032 - 6.20.032
6.40.040	6.05.040 - 6.10.040
6.40.041	6.15.040 - 6.20.040
6.40.050	6.05.050 - 6.10.050
6.40.051	6.15.050 - 6.20.050
6.40.063	6.05.063 - 6.10.063
6.40.064	6.15.063 - 6.20.063
6.40.075	6.15.075 - 6.20.075
6.40.090	6.15.090 - 6.20.090
6.40.110	6.15.110 - 6.20.110

VITON (F.P.M Colour = green)

ART.CODE	BALL VALVE
6.42.020	6.06.016 - 6.06.020
6.42.021	6.16.016 - 6.16.020
6.42.025	6.06.025
6.42.026	6.16.025
6.42.032	6.06.032
6.42.033	6.16.032
6.42.040	6.06.040
6.42.041	6.16.040
6.42.050	6.06.050
6.42.051	6.16.050
6.42.063	6.06.063
6.42.064	6.16.063
6.42.075	6.16.075
6.42.090	6.16.090
6.42.110	6.16.110

PVC-U METRIC

TECHNICAL DATA BALL VALVES

Technische info kogelkranen
Technische Daten Kugelhahne
Caractéristiques
techniques vanne à boisseau
Dati tecnici valvola a sfera
Información técnico
válvula de bola

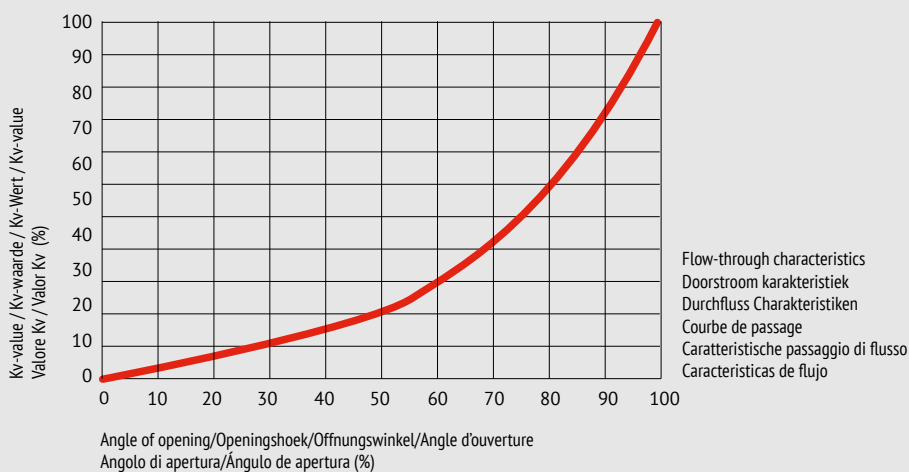
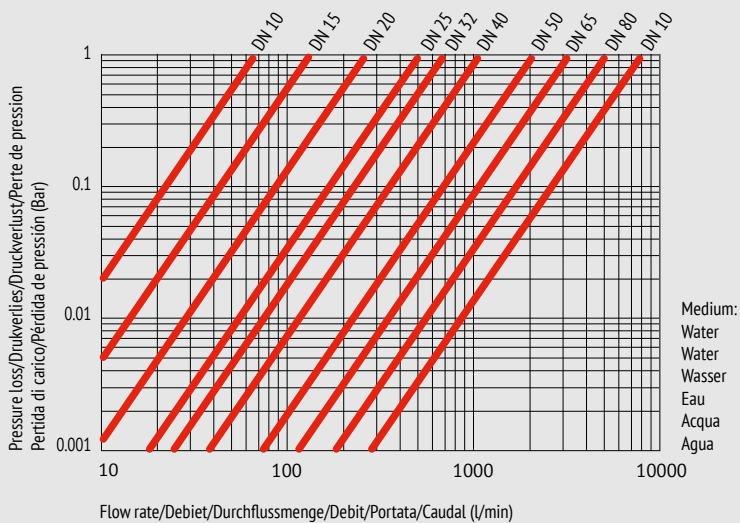
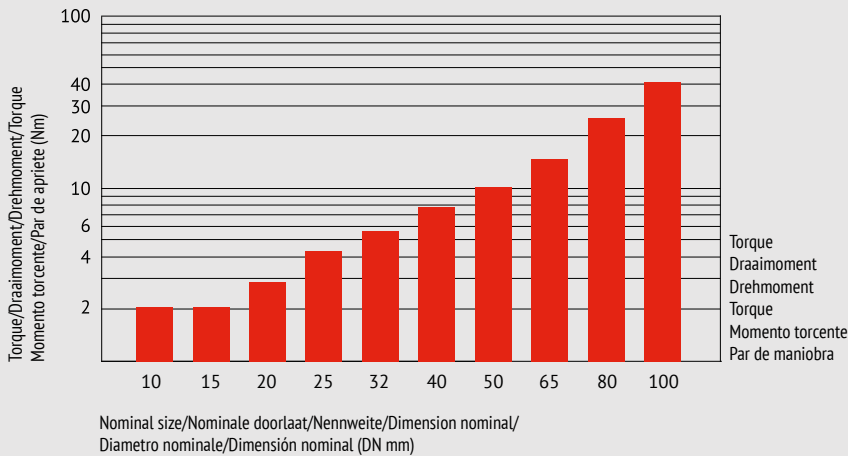

TECHNICAL DATA BALL VALVES

Technische info kogelkranen
Technische Daten Kugelhahne
Caractéristiques techniques vanne à boisseau
Dati tecnici valvola a sfera
Información técnico
válvula de bola

Every single valve has been tested on leaks.
Iedere kogelkraan is afzonderlijk getest op lekkage.
Jeder Kugelhahn wird geprüft auf Leckage.
Chaque vanne est contrôlée pour son étanchéité.
Valvole controllate al 100% per le perdite idrauliche.
Cada válvula de bola pasa un control de estanquidad.

Seals	: Seats O-Rings	: TEFLON filled PE : Standard E.P.D.M., optional delivery: Viton®
Afdichtingen	: Zittingen O-Ringen	: TEFLON gevuld PE : Standaard E.P.D.M., als optie leverbaar: Viton®
Dichtungen	: Kugeldichtungen O-Ringe	: TEFLON gefülltes PE : Standard E.P.D.M., auch lieferbar: Viton®
Garniture	: Sièges Joint torique	: PE avec TEFLON : Standard E.P.D.M., livrable optionelle: Viton®
Tenute	: Sede O-Ring	: PE caricata con TEFLON : Standard E.P.D.M., a richiesta: Viton®
Juntas	: Junta de bola Junta tórica	: PE con TEFLON : E.P.D.M. estándar, FPM (Viton®) opcional

PVC-U METRIC

LABORATORY BALL VALVE

Laboratorium kogelkraan
Laboratorium Kugelhahn
Vanne a boisseau laboratoire
Valvula a sfera laboratorio
Válvula de bola labororio

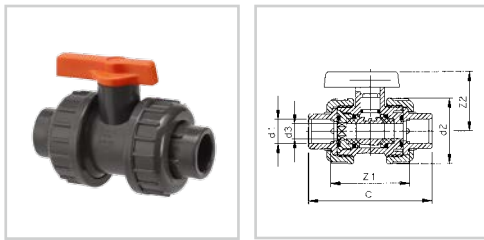

ART.CODE	d1	d2	d3	Z1	Z2	C	DN	PN	QUANTITY
6.01.012	12	39	8	46	35	70	8	16	50
6.01.016	16	43	10	52	39	80	10	16	50

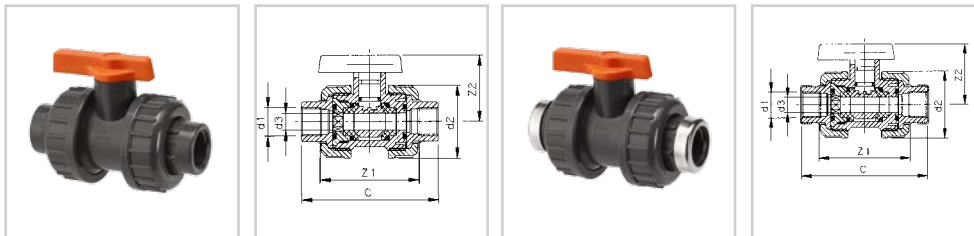

TYPE A

TYPE B

ART.CODE	d1	d2	d3	Z1	Z2	C	DN	TYPE	PN	QUANTITY
6.02.012	1/4" (F)	39	8	46	35	70	8	A	16	50
6.02.016	3/8" (F)	43	10	56	39	80	10	B	16	50

LABORATORY BALL VALVE

Laboratorium kogelkraan
Laboratorium Kugelhahn
Vanne a boisseau laboratoire
Valvula a sfera laboratorio
Válvula de bola labororio



TYPE A

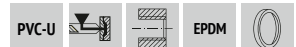

TYPE B

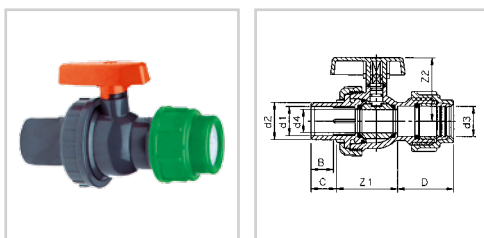

ART.CODE	d1	d2	d3	d4	Z1	Z2	B	C	D	DN	PN	QUANTITY
6.00.016	25	32	16	20	70	55	19	22	42	20	10	50
6.00.020	25	32	20	20	68	55	19	22	47	20	10	50
6.00.025	25	32	25	20	66	55	19	22	51	20	10	50
6.00.032	32	40	32	25	70	65	22	26	57	25	10	25

BALL VALVE FOR SUBSTRATE

Kogelkraan voor substraat
Kugelhahn für Nährboden Anlagen
Vanne à boisseau pour substrat
Vavula a sfera per cultura substrato
Válvula de bola para substrato nutritivo



PVC-U METRIC

SLIDE VALVE

Schuifafsluiter
Absperrschieber
Vanne à Guillotine
Valvula Ghigliottina
Válvula de guillotina

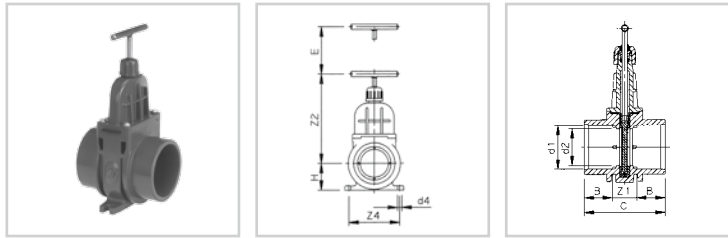

ART.CODE	d1	d2	d4	Z1	Z2	Z4	B	C	E	H	QUANTITY
6.80.050	50	42	7	29	139	76	31	91	52	40	25
6.80.063	63	54	9	38	164	98	38	114	65	51.5	12
6.80.075	75	64	9	39	187	112	44	127	73	57.5	8
6.80.090	90	76	9	45	218	134	51	147	91	71	6
6.80.110	110	92	9	54	250	158	61	176	108	81	4



SLIDE VALVE

Schuifafsluiter
Absperrschieber
Vanne à Guillotine
Valvula Ghigliottina
Válvula de guillotina

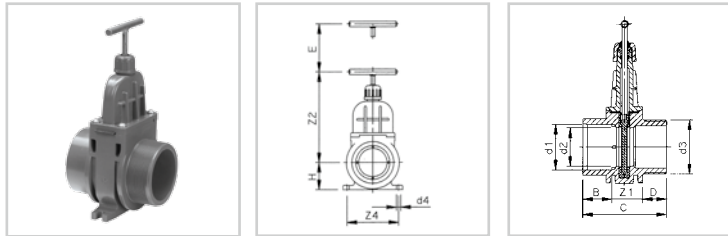

ART.CODE	d1	d2	d3	d4	Z1	Z2	Z4	B	C	D	E	H	QUANTITY
6.85.050	50	42	2" (M)	7	35	139	76	31	92	27	52	40	25
6.85.063	63	54	2½" (M)	9	44	164	98	38	112	31	65	51.5	12
6.85.075	75	64	3" (M)	9	49	187	112	44	126	34	73	57.5	8



SLIDE VALVE

Schuifafsluiter
Absperrschieber
Vanne à Guillotine
Valvula Ghigliottina
Válvula de guillotina

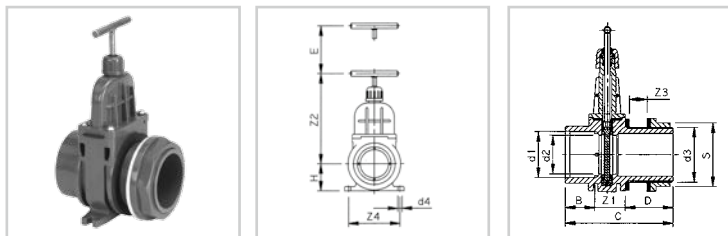

ART.CODE	d1	d2	d3	d4	Z1	Z2	Z3	Z4	B	C	D	E	S	H	QUANTITY
6.90.050	50	42	2" (M)	7	35	139	0-21	76	31	117	52	52	69	40	25
6.90.063	63	54	2½" (M)	9	44	164	0-23	98	38	133	52	65	85	51.5	12
6.90.075	75	64	3" (M)	9	49	187	0-20	112	44	148	56	73	100	57.5	8
6.90.090	90	76	M113 (M)	9	54	218	0-20	134	51	166	62	91	127	71	4
6.90.110	110	92	M133 (M)	9	65	250	0-22	158	61	191	66	108	147	81	4



REPLACEMENT KIT

Vervang set
Ersatzungs kit
Jeu de rechange
Kit di pezzi di ricambio
Kit recambio



ART.CODE	DESCRIPTION	d1	P max
6.45.050	Kit for 6.80.050/6.85.050/6.90.050	50	3.0
6.45.063	Kit for 6.80.063/6.85.063/6.90.063	63	2.0
6.45.075	Kit for 6.80.075/6.85.075/6.90.075	75	1.5
6.45.090	Kit for 6.80.090/6.90.090	90	1.0
6.45.110	Kit for 6.80.110/6.90.110	110	1.0

EPDM

TECHNICAL DATA SLIDE VALVE

Technische info schuifafsluiter
Technische Daten Absperschieber
Caractéristiques techniques vanne à guillotine
Dati tecnici val-vula ghigliottina
Información técnico valvula de guillotina

P max

Maximum pressure, at which manual operation of the slide remains possible.
Maximale druk, waarbij handbediening van de schuif mogelijk blijft.
Maximale Druck, wobei der Handbetrieb von dem Absperrer möglich bleibt.
Pression maximale, pres de laquell la commande de la guillotine reste possible.
Pressione massima, con mantenimento del controllo manuale della slitta.
Máxima presión sin pérdida de control manual del mecanismo de válvula corredera.

Data/ Informatie/ Daten/ Caractéristiques/ Dati/ Información

Easy maintenance, retractable seal.
Entretien simple par joint démontable.
Eenvoudig onderhoud door uitneembare pakking.
Facilità di manutenzione grazie alla guarnizione rimovibile.
Einfache Wartung durch herausnehmbare Dichtung.
Mantenimiento sencillo gracias a su car casa extraíble.

Leak free in all positions.
Etanche dans toutes les positions.
Lekvrij in alle posities.
A prova di perdita in tutte le posizione.
Lecksicher in allen Positionen.
Estanqueidad garantizada en todas las posiciones.

Adjustable seal on spindle.
Joint remontable sur l'arbre de commande.
Nastelbare pakking langs bedieningsas.
Ulteriore regolazione dellaguarnizione lungo l'albero di controllo.
Herstellbare Dichtung entlang der Betriebsachse.
Empaquetadura reajustable a lo largo del eje de maniobra.

Dutch Patent no. 1008658.
Patent neerlandais no. 1008658.
Nederlands Patent no. 1008658.
Olandese brevetto no. 1008658.
Niederländisches Patent Nr. 1008658.
Holandés patente no. 1008658.

European Patent no. 0943850.
Patent Européen no. 0943850.
Europees Patent no. 0943850.
Europeo brevetto no. 0943850.
Europäisches Patent Nr. 0943850.
Europea patente no. 0943850.

USA Patent no. 6.375.157.
Patent USA no. 6.375.157.
USA Patent no. 6.375.157.
USA brevetto no. 6.375.157.
USA Patent Nr. 6.375.157.
USA patente no. 6.375.157.

PVC-U METRIC

SLIDE VALVE

Schuifafsluiter
Absperrschieber
Vanne à Guillotine
Valvula Ghigliottina
Válvula de guillotina

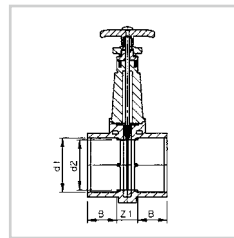
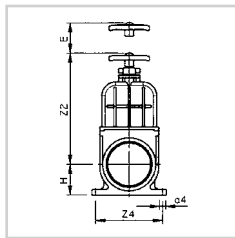

Female solvent weld
Inwendige lijmverbinding
Klebemuffe
À coller femelle
Femmina per incollaggio
Encolor hembra



ART.CODE	d1	d2	d4	Z1	Z2	Z4	B	E	H	P max	QUANTITY
6.80.111	110	92	9	54	290	158	61	107	81	0.5	4
6.80.161	160	150	11	55	388	240	86	163	108	0.5	1
6.80.201	200	192	13	48	450	275	107	200	128	0.5	1

SLIDE VALVE

Schuifafsluiter
Absperrschieber
Vanne à Guillotine
Valvula Ghigliottina
Válvula de guillotina

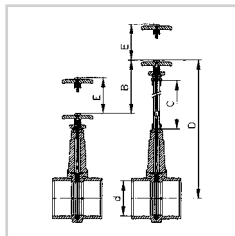

ART.CODE	d	B	C	D	E	P max	QUANTITY
6.80.111.1	110	500	478	788	107	0.5	1
6.80.111.2	110	1000	978	1288	107	0.5	1
6.80.111.3	110	1500	1478	1788	107	0.5	1
6.80.111.4	110	2000	1978	2288	107	0.5	1
6.80.161.1	160	500	478	888	163	0.5	1
6.80.161.2	160	1000	978	1388	163	0.5	1
6.80.161.3	160	1500	1478	1888	163	0.5	1
6.80.161.4	160	2000	1978	2388	163	0.5	1
6.80.201.1	200	500	478	950	200	0.5	1
6.80.201.2	200	1000	978	1450	200	0.5	1
6.80.201.3	200	1500	1478	1950	200	0.5	1
6.80.201.4	200	2000	1978	2450	200	0.5	1

PVC-U METRIC

SLIDE VALVE

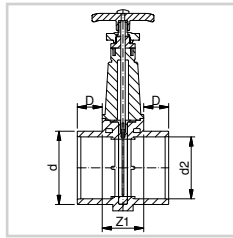
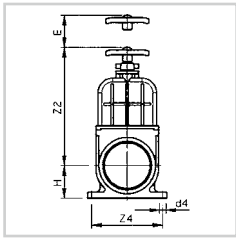

Male solvent weld
 Uitwendige lijmverbinding
 Klebestutzen
 À coller male
 Maschio per incollaggio
 Encolor macho

Schuifafsluiter
 Absperrschieber
 Vanne à Guillotine
 Valvula Ghigliottina
 Válvula de guillotina

ART.CODE	d	d2	d4	Z1	Z2	Z4	D	E	H	P max	QUANTITY
6.82.126	125	95	9	78	290	158	69	107	81	0.5	4

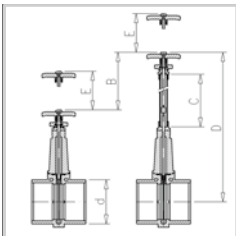

SLIDE VALVE

Schuifafsluiter
 Absperrschieber
 Vanne à Guillotine
 Valvula Ghigliottina
 Válvula de guillotina

ART.CODE	d	B	C	D	E	P max	QUANTITY
6.82.126.1	125	500	478	788	107	0.5	1
6.82.126.2	125	1000	978	1288	107	0.5	1
6.82.126.3	125	1500	1478	1788	107	0.5	1
6.82.126.4	125	2000	1978	2288	107	0.5	1



PVC-U METRIC

BUTTERFLY VALVE

Vlinderklep
Absperriklappe
Vanne à papillon
Valvola a farfalla
Válvula de mariposa

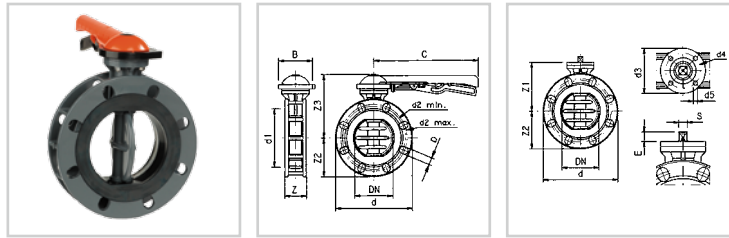

ART.CODE	Dia	d	d1	d2	Z	Z1	Z2	Z3	B	C	NxD	DN	PN	QUANTITY
6.70.075	75	185	106	128/144	53	134	92.5	174	108	270	4x19	65	10	1
6.70.090	90	200	125	145/160	56	141.5	100	181	108	270	8x19	80	10	1
6.70.110	110	220	150	165/190	63	151.5	110	192	108	270	8x19	100	10	1
6.70.140	140	250	188	204/215	71	162.5	125	203	108	340	8x23	125	10	1
6.70.160	160	285	214	230/242	78	180	142.5	221	108	340	8x23	150	6	1
6.70.225	225	340	266	280/298	81	233	170	289	150	420	8x23	200	6	1

ART.CODE	Dia	d3	d4	d5	E	S	ISO 5211
6.70.075	75	90	70	8.5	11	11	ISO 5211 - F05/F07 - Y - L - 11
6.70.090	90	90	70	8.5	15	14	ISO 5211 - F05/F07 - Y - L - 14
6.70.110	110	90	70	8.5	15	14	ISO 5211 - F05/F07 - Y - L - 14
6.70.140	140	90	70	8.5	19	17	ISO 5211 - F07 - Y - L - 17
6.70.160	160	90	70	8.5	19	17	ISO 5211 - F07 - Y - L - 17
6.70.225	225	125	102	11	23	22	ISO 5211 - F10 - Y - L - 22

BUTTERFLY VALVE

Vlinderklep
Absperriklappe
Vanne à papillon
Valvola a farfalla
Válvula de mariposa



ART.CODE	Dia	TORQUE (MIN.)	ISO 5211
SPE670075	75	20 Nm	ISO 5211 - F05/F07 - Y - L - 11
SPE670090	90	30 Nm	ISO 5211 - F05/F07 - Y - L - 14
SPE670110	110	60 Nm	ISO 5211 - F05/F07 - Y - L - 14
SPE670140	140	100 Nm	ISO 5211 - F07 - Y - L - 17
SPE670160	160	120 Nm	ISO 5211 - F07 - Y - L - 17
SPE670225	225	180 Nm	ISO 5211 - F10 - Y - L - 22

Direct mounting for actuators according to ISO 5211...
Directe aansluiting voor aandrijvingen volgens ISO 5211...
Direkte Anschluß für Armaturen nach ISO 5211...
Assemblage directement pour des actionneurs suivant ISO 5211...
Montaggio diretto di attuatori dalla ISO 5211...
Montaje directo de actuador según ISO 5211...

PVC-U METRIC

BUTTERFLY VALVE

Vlinderklep
Absperklappe
Vanne à papillon
Valvola a farfalla
Válvula de mariposa

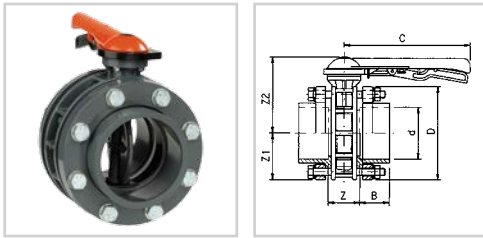

ART.CODE	d	D	Z	Z1	Z2	B	C	DN	QUANTITY
6.78.063	63	185	77	92.5	174	38	270	65	1
6.78.075	75	185	59	92.5	174	44	270	65	1
6.78.090	90	200	66	100	181	51	270	80	1
6.78.110	110	220	73	110	192	61	270	100	1
6.78.125	125	250	113	125	203	69	270	125	1
6.78.140	140	250	81	125	203	76	340	125	1
6.78.160	160	285	88	142.5	221	86	340	150	1
6.78.200	200	340	149	170	289	106	420	200	1
6.78.225	225	340	95	170	289	119	420	200	1



EXTENDED BUTTERFLY VALVE

Verlengde vlinderklep
Absperklappe verlängert
Vanne à papillon prolongé
Esteso valvola a farfalla
Extendido válvula de mariposa

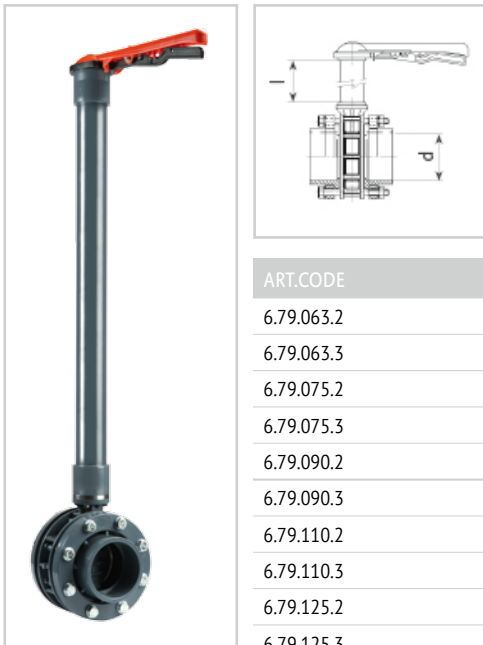

ART.CODE	d	L
6.79.063.2	63	1000
6.79.063.3	63	1500
6.79.075.2	75	1000
6.79.075.3	75	1500
6.79.090.2	90	1000
6.79.090.3	90	1500
6.79.110.2	110	1000
6.79.110.3	110	1500
6.79.125.2	125	1000
6.79.125.3	125	1500
6.79.140.2	140	1000
6.79.140.3	140	1500
6.79.160.2	160	1000
6.79.160.3	160	1500
6.79.200.2	200	1000
6.79.200.3	200	1500
6.79.225.2	225	1000
6.79.225.3	225	1500



PVC-U METRIC

KIT FOR BUTTERFLY VALVE

Kit voor Vlinderklep
Kit für Absperrklappe
Kit pour vanne à papillon
Kit para valvola a farfalla
Kit para válvula de mariposa

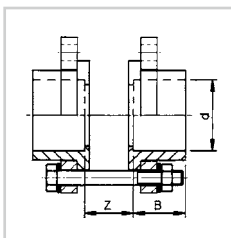

ART.CODE	d	Z	B	DN	QUANTITY
6.76.063	63	77	38	65	1
6.76.075	75	59	44	65	1
6.76.090	90	66	51	80	1
6.76.110	110	73	61	100	1
6.76.125	125	113	69	125	1
6.76.140	140	81	76	125	1
6.76.160	160	88	86	150	1
6.76.200	200	149	106	200	1
6.76.225	225	95	119	200	1

PVC-U



TECHNICAL DATA BUTTERFLY VALVE

Technische info vlinderklep
 Technische Daten Absperrklappe
 Caractéristiques techniques vanne à papillon
 Dati tecnici val-vula a farfalla
 Información técnico válvula de mariposa

Data/ Informatie/ Daten/ Caractéristiques/ Dati/ Información

Body	: PVC-U	Corps	: PVC-U
Seals	: EPDM	Garniture	: EPDM
Shaft	: INOX 316	Tige	: INOXIDABLE 316
Huis	: PVC-U	Corpo	: PVC-U
Afdichting	: EPDM	Tenute	: EPDM
As	: RVS 316	Stelo	: ACCIAIO INOX 316
Gehäuse	: PVC-U	Cuerpo	: PVC-U
Dichtungen	: EPDM	Juntas	: EPDM
Welle	: EDELSTAHL 316	Eje	: INOX 316

Kv-Value/ Kv-Waarde/ Kv-Wert/ Kv-Value/ Valore Kv/ Valor Kv

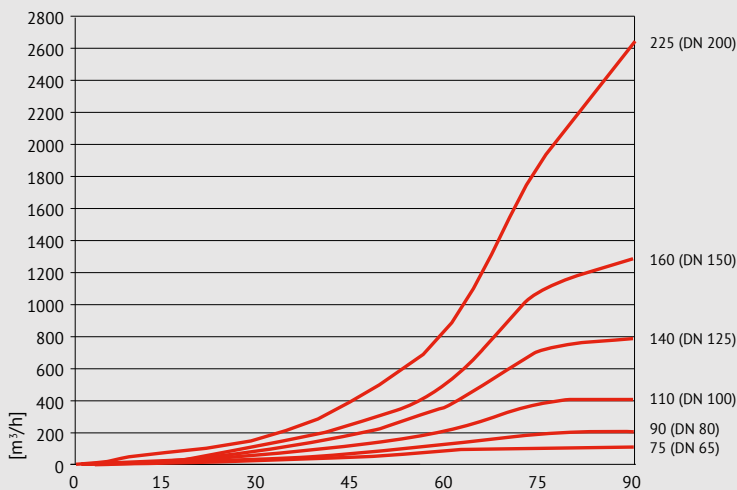

Angle of opening, Openingshoek, Öffnungswinkel, Angle d'ouverture,
 Angulo di apertura, Ángulo de apertura

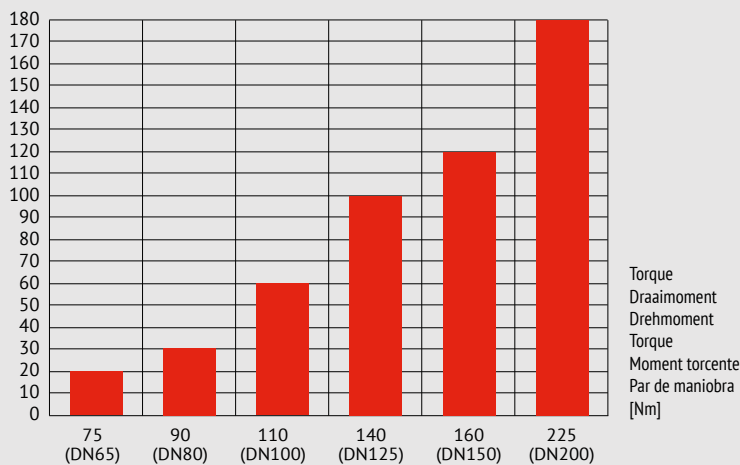

Torque
 Draaimoment
 Drehmoment
 Torque
 Moment torcente
 Par de maniobra
 [Nm]

PVC-U METRIC

CHECKVALVE

Terugslagklep
Rückschlagventil
Soupape de retenue
Valvola diritegno
Vulvelas antiretorno

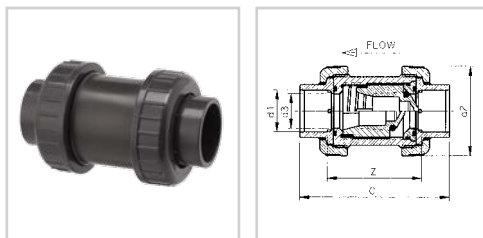

ART.CODE	d1	d2	d3	Z	C	DN	PN	P	KV	QUANTITY
6.60.016	16	43	10	46	75	10	16	0.05	61	50
6.60.020	20	59	17	58	91	15	16	0.05	147	50
6.60.025	25	64	22	62.5	101.5	20	16	0.05	263	50
6.60.032	32	73	27	75.5	120.5	25	16	0.05	388	50
6.60.040	40	86	33	90	143	32	16	0.05	682	30
6.60.050	50	102	40	108	171	40	16	0.05	1052	10
6.60.063	63	124	50	129	205.5	50	16	0.05	1658	10
6.60.075	75	151	67	164	252	65	10	0.10	1933	1
6.60.090	90	178.5	83	188	291	80	10	0.10	3166	1
6.60.110	110	215.5	99	225	348	100	10	0.10	4650	1

CHECKVALVE

Terugslagklep
Rückschlagventil
Soupape de retenue
Valvola diritegno
Vulvelas antiretorno

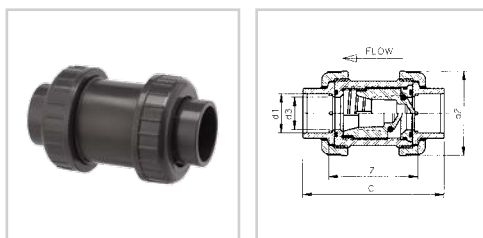

ART.CODE	d1	d2	d3	Z	C	DN	PN	P	Kv	QUANTITY
6.61.016	16	43	10	46	75	10	16	0.05	61	50
6.61.020	20	59	17	58	91	15	16	0.05	147	50
6.61.025	25	64	22	62.5	101.5	20	16	0.05	263	50
6.61.032	32	73	27	75.5	120.5	25	16	0.05	388	50
6.61.040	40	86	33	90	143	32	16	0.05	682	30
6.61.050	50	102	40	108	171	40	16	0.05	1052	10
6.61.063	63	124	50	129	205.5	50	16	0.05	1658	10
6.61.075	75	151	67	164	252	65	10	0.10	1933	1
6.61.090	90	178.5	83	188	291	80	10	0.10	3166	1
6.61.110	110	215.5	99	225	348	100	10	0.10	4650	1

P
Openingsdruk
Opening pressure
Öffnungsdruck
Pression d'ouverture
Pressione in apertura
Presión de apertura

Kv
Flow [l/min] waarbij Δp is 1 bar, bepaald volgens DIN EN 60534-2-3
Flow [l/min] by which Δp is 1 bar, determined according to DIN EN 60534-2-3
Fluss [l/min] wobei Δp 1 bar ist, festgesetzt zufolge DIN EN 60534-2-3
Courant [l/min] par lequel Δp est 1 bar, déterminé par DIN EN 60534-2-3
Corrente [l/min] fra cui Δp é 1 bar, determinato secondo DIN EN 60534-2-3
Caudal [l/min] con un Δp de 1 bar, determinado según DIN EN 60534-2-3

PVC-U METRIC

COLLAR MALE SPIGOT (OPTION)

Inlegstuk uitwendig lijm
Bundbuchse Klebestutzen
Collet à coller male
Collare maschio
Portabrida encolar macho

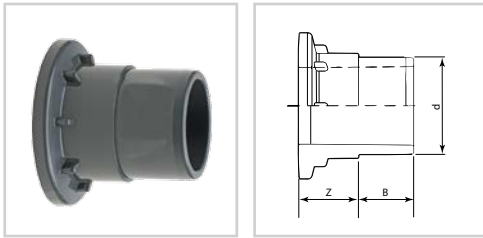

ART.CODE	d	Z	B	DN	QUANTITY
6.25.050	50	33	31	40	1
6.25.063	63	39	38	50	1



COLLAR SOLVENT SOCKET (PARTS)

Inlegstuk inwendig lijm
Bundbuchse Klebemuffe
Collet à coller femelle
Collare a attacchi incollaggio
Portabrida encolar

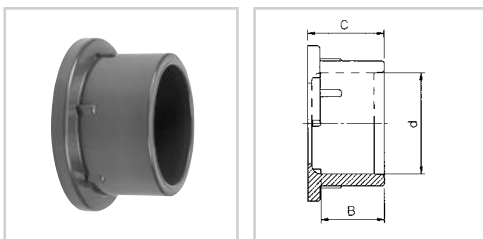

ART.CODE	d	B	C	DN	QUANTITY
6.26.016	16	14	20.5	10	50
6.26.020	20	16	20.5	15	50
6.26.025	25	19	23.5	20	50
6.26.032	32	22	27.5	25	50
6.26.040	40	26	32.0	32	25
6.26.050	50	31	38.0	40	20
6.26.063	63	38	49.0	50	20
6.26.075	75	44	54.5	65	10
6.26.090	90	51	63.0	80	10
6.26.110	110	61	76.5	100	10



COLLAR FEMALE THREADED (OPTION)

Inlegstuk inwendig draad
Bundbuchse Innengewinde
Collet taraudé
Collare attacchi filetati femmina
Portabrida encolar rosca hembra

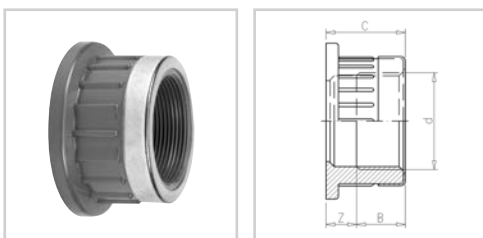

ART.CODE	d	B	C	Z	DN	QUANTITY
6.30.016	3/8" (F)	13	20.5	7.5	10	50
6.30.020	1/2" (F)	17	20.5	3.5	15	50
6.30.025	3/4" (F)	19	23.5	4.5	20	50
6.30.032	1" (F)	21	27.5	6.5	25	50
6.30.040	1 1/4" (F)	21	32.0	11	32	25
6.30.050	1 1/2" (F)	29	38.0	9	40	20
6.30.063	2" (F)	32	49.0	17	50	20
6.30.075	2 1/2" (F)	36	54.5	18.5	65	10
6.30.090	3" (F)	39	63.0	24	80	10
6.30.110	4" (F)	46	76.5	30.5	100	10



PVC-U METRIC

PE CONNECTOR FOR CHECK VALVE (OPTION)

PE inlegdeel voor terugslagklep
PE Einlegeeteil für Rückschlagventil
Pièce folle en PE pour soupape de retenue
Collare PE valvola di ritegno
Portabrida PE válvula antirretorno

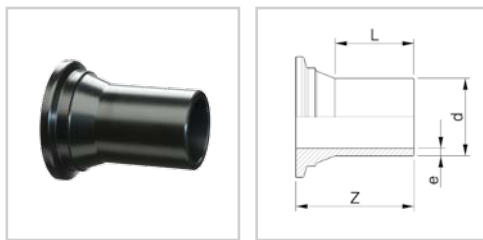

ART.CODE	d	Z	L	e	SDR	(bar) P*	QUANTITY
6.31.020	20	67	45	2.0	11	12.5	25
6.31.025	25	68	45	2.3	11	12.5	25
6.31.032	32	71	45	3.0	11	12.5	25
6.31.040	40	80	50	3.7	11	12.5	15
6.31.050	50	89	57	4.6	11	12.5	10
6.31.063	63	105	70	5.8	11	12.5	5
6.31.064	63	105	70	3.8	17	7.5	5
6.31.075	75	123	81	6.8	11	7.5	5
6.31.076	75	123	81	4.5	17	7.5	5
6.31.090	90	137	90	8.2	11	7.5	3
6.31.091	90	137	90	5.4	17	7.5	3

*Remarks

- Maximum working pressure (P) for water at 20°C and constant load.
- For use at higher temperatures or varying loads, additional reduction factors must be taken into account.

*Opmerkingen

- Maximale werkdruk (P) voor water van 20°C en bij constante belasting.
- Voor gebruik bij hogere temperaturen of wisselende belastingen moet rekening gehouden worden met extra reductiefactoren.

*Bemerkungen

- Maximaler Betriebsdruck (P) für Wasser bei 20°C und bei konstanter Belastung.
- Für Einsatz bei höheren Temperaturen oder wechselnden Belastung müssen zusätzliche Reduktionsfaktoren berücksichtigt werden.

*Remarques

- Pression de service maximale (P) pour l'eau à 20°C et à charge constante.
- Pour utilisation à des températures élevées ou des charges variables, des facteurs de réduction additional doit être pris en compte.

COLLAR MALE THREADED (OPTION)

Inlegstuk uitwendig draad
Bundbuchse Aussengewinde
Collet fileté
Collare attacchi filetati maschio
Portabrida encolar rosca macho

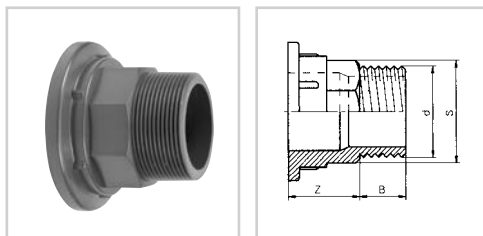

ART.CODE	d	Z	B	S	DN	QUANTITY
6.32.020	½" (M)	21	17	24	15	50
6.32.025	¾" (M)	20	19	29	20	50
6.32.032	1" (M)	25	21	36	25	50
6.32.040	1¼" (M)	31	21	44	32	20
6.32.050	1½" (M)	29	29	52	40	20
6.32.063	2" (M)	36	32	63	50	20